

RS 4-14 GEN. 3

RS



GEHL®

Capacities		Metric	Imperial
Max. capacity		1995.81 kg	4400 lb
Max. lifting height		4.34 m	14 ft 3 in
Max. outreach		2.74 m	9 ft
Breakout force with bucket		1886 daN	1886 daN
Weight and dimensions			
Overall length to carriage	l11	3.64 m	11 ft 11 in
Length to face of forks	l2	3.58 m	11 ft 9 in
Overall width	b1	1.49 m	4 ft 11 in
Overall height	h17	1.91 m	6 ft 3 in
Wheelbase	y	2.13 m	7 ft
Ground clearance	m4	0.24 m	9 in
Overall cab width	b4	0.80 m	2 ft 7 in
Tilt-up angle	a4	12 °	12 °
Tilt-down angle	a5	116 °	116 °
External turning radius (over tyres)	Wa1	3.07 m	10 ft 1 in
Unladen weight (with forks)		4190 kg	9237 lb
Overall weight		4189.83 kg	9237 lb
Tires type		Pneumatic	Pneumatic
Standard tires		Camso SKS-532 - 12 - 16.5-12PR	Camso SKS-532 - 12 - 16.5-12PR
Engine			
Engine brand		Kubota	Kubota
Engine norm		Stage V	Stage V
Engine model		2607-CR-E5	2607-CR-E5
Number of cylinders / Capacity of cylinders		4 - 2615 cm ³	4 - 160 in ³
I.C. Engine power rating - Power (kW)		56.30 Hp / 42 kW	56.30 Hp / 42 kW
Max. torque / Engine rotation		174 Nm @ 2700 rpm	128 ft/lbs @ 2700 rpm
Drawbar pull		2850 daN	2850 daN
Drawbar pull (Laden)		2850 daN	2850 daN
Transmission			
Transmission type		Hydrostatic	Hydrostatic
Number of gears (forward / reverse)		2 / 2	2 / 2
Max. travel speed		25 km/h	16 mi/h
Parking brake		Automatic Negative Hand-brake	Automatic Negative Hand-brake
Service brake		Disk brake on the cadran shaft	Disk brake on the cadran shaft
Axle Manufacturer		Dana	Dana
Hydraulics			
Hydraulic pump type		Gear pump	Gear pump
Hydraulic flow / Pressure		77.41 l/min-235 bar	20 US gpm-3408 PSI
Tank capacities			
Engine oil		10.20 l	3 US gal
Hydraulic oil		68.14 l	18 US gal
Fuel tank		60 l	16 US gal
Miscellaneous			
Steering wheels (front / rear)		2 / 2	2 / 2
Drive wheels (front / rear)		2 / 2	2 / 2
Safety / Safety cab homologation		Standard EN 15000 / ROPS/FOPS	Standard EN 15000 / ROPS/FOPS
Controls		Single joystick with FNR	Single joystick with FNR

RS 4-14 Gen: 3 - Load chart

Machine on tyres with forks Imperial

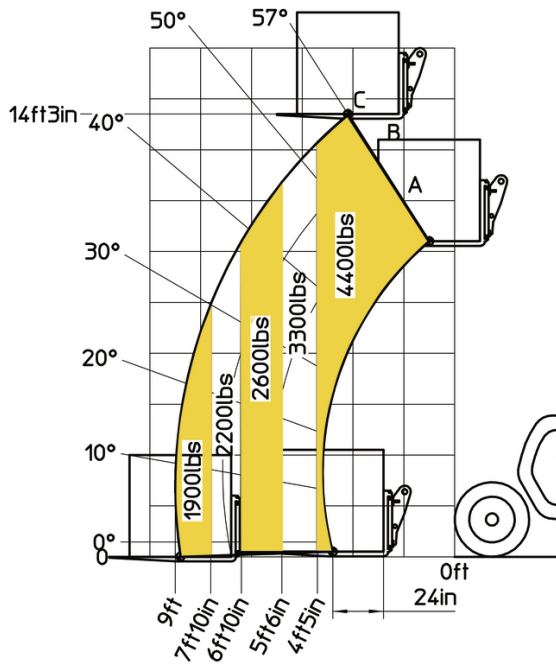



GEHL®

Siège Social
P.O. Box 179 - One Gehl Way - West Bend, WI, USA 53095
Tel: (262) 334-9461 - Fax: (262) 338-7517
www.gehl.com



This brochure describes versions and configuration options for Gehl products which may be fitted with different equipment. The equipment described in this brochure may be standard, optional or not available depending on version. Gehl reserves the right to change the specifications shown and described at any time and without prior warning. The manufacturer is not liable for the specifications given. For more information, contact your Gehl dealer. Non-contractual document. Product descriptions may differ from actual products. List of specifications is not comprehensive. The logos and visual identity of the company are the property of Gehl and may not be used without authorization. All rights reserved. The photos and diagrams contained in this brochure are provided for information only.

MANITOU EQUIPMENT AMERICAS, LLC - Limited company with board of directors - Share capital: 39,668,399 euros - 857 802 508 RCS West Bend