

Technical sheet :

# MTA 5519 S3



 **MANITOU**  
HANDLING YOUR WORLD

Capacities		Imperial
Max. capacity		5501 lb
Max. lifting height		19 ft
Max. outreach		11 ft
Weight and dimensions		
Overall length to carriage	l11	12 ft 4 in
Overall width	b1	5 ft 11 in
Overall height	h17	6 ft 4 in
Wheelbase	y	7 ft 6 in
Ground clearance	m4	10 in
Overall cab width	b4	28 in
Tilt-up angle	a4	12 °
Tilt-down angle	a5	100 °
External turning radius	Wa3	11 ft
Unladen weight (with forks)		9700 lb
Standard tires		12 x 16.5
Performances		
Lifting		8 s
Lowering		5 s
Extension		7 s
Retraction		6 s
Crowd		4 s
Dump		4 s
Engine		
Engine brand		Yanmar
Engine norm		Tier 4 final
Engine model		4TNV98
Number of cylinders / Capacity of cylinders		4 - 0.20 in³
I.C. Engine power rating - Power		68 Hp / 50.70 kW
Max. torque / Engine rotation		173 ft/lbs @ 235 rpm
Transmission		
Transmission type		Hydrostatic
Number of gears (forward / reverse)		2 / 2
Parking brake		Hydraulic spring release SAHR
Service brake		Wet disc brakes
Axle Manufacturer		Dana
Hydraulics		
Hydraulic pump type		Gear pump
Hydraulic flow / Pressure		22 US gpm-3350 PSI
Tank capacities		
Engine oil		2 US gal
Hydraulic oil		18 US gal
Fuel tank		17 US gal
Miscellaneous		
Steering wheels (front / rear)		2 / 2
Drive wheels (front / rear)		2 / 2
Safety cab homologation		ROPS/FOPS
Controls		Single Joystick FNR

MTA 5519 S3 - Dimensional drawing

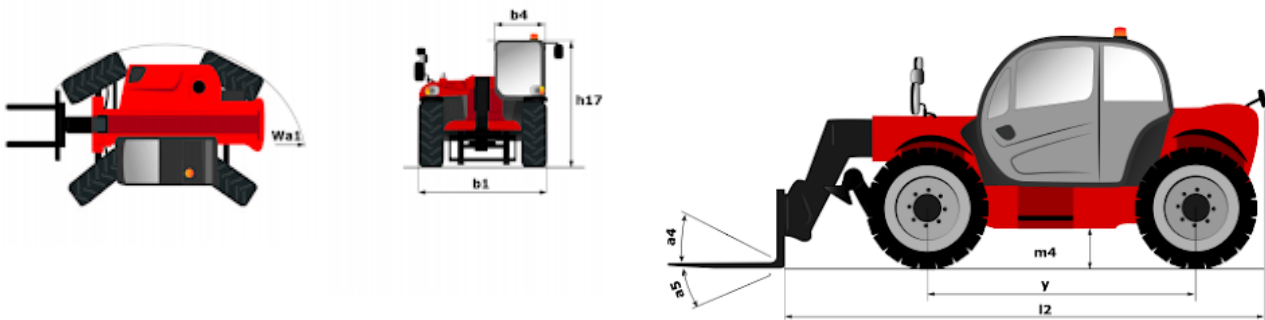

# MTA 5519 S3 - Load chart

Machine on tires with forks Imperial

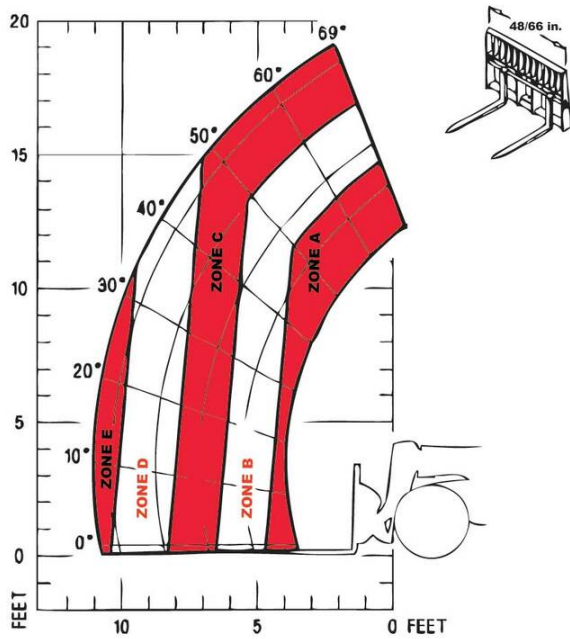

183489



**Head Office**

B.P. 249 - 430 rue de l'Aubinière

44150 Ancenis Cedex - France

Tel: +33 (0)2 40 09 10 11 - Fax: +33 (0)2 40 09 10 97

[www.manitou.com](http://www.manitou.com)



This publication provides a description of the configuration versions and options for Manitou products, which may differ for equipment. The equipment presented in this brochure may be part of a series, as an option, or it may not be available, depending on the versions. Manitou reserves the right, at any time and without notice, to amend the specifications described and represented. The specifications provided do not bind the manufacturer. For more details, please contact your Manitou agent. This is not a contractually binding document. The presentation of the products is not contractually binding. List of specifications non-exhaustive. The logos as well as the visual identity of the company are owned by Manitou and cannot be used without authorisation. All rights reserved. The photos and diagrams contained in this brochure are only provided for consultation and information purposes.

MANITOU BF SA - Limited company with board of directors - Share capital: 39,668,399 euros - 857 802 508 RCS Nantes