

Ficha técnica :

280 TJ ST5



Capacities		Métrico
Working height	h21	27.73 m
Platform height	h7	25.73 m
Max. outreach		21.45 m
Pendular arm rotation (top / bottom)		+56.80 ° / -62 °
Platform capacity / capacity (maximum)	Q	240 kg / 350 kg
Turret rotation		360 °
Platform rotation (right / left)		90 ° / 90 °
Number of people (indoor / outdoor)		3 / 2
Weight and dimensions		
Platform weight*		16500 kg
Platform dimensions (length x width)	lp / ep	2.30 m x 0.90 m
Floor height (access)	h20	0.40 m
Overall length	l1	11.36 m
Overall width	b1	2.48 m
Overall height	h17	2.73 m
Overall length (stowed)	l9	8.09 m
Overall height (stowed)	h18 ***	2.71 m
Jib length	l13	3.80 m
Telescopic jib length retracted / extended		2800 mm / 4300 mm
Counterweight offset (turret at 90°)	a7	1.43 m
Counterweight Oversize / Reach		1.45 m
External turning radius	Wa3	4.35 m
Ground clearance at centre of wheelbase	m2	0.41 m
Wheelbase	y	2.80 m
Performances		
Drive speed - stowed		4.50 km/h
Drive speed - raised		0.80 km/h
Gradeability		35 %
Permissible leveling		4 °
Wheels		
Tires type		Solid Tires Cured-On
Drive wheels (front / rear)		2 / 2
Steering wheels (front / rear)		2 / 2
Braking wheels (front / rear)		2 / 2
Engine/Battery		
Engine brand / model		Yanmar - 4TNV88C
Engine norm		Stage V
I.C. Engine power rating / Power		46 Hp / 34.30 kW
Miscellaneous		
Ground Pressure		21.30 dan/cm2
Hydraulic Pressure		400 bar
Hydraulic tank capacity		94 l
Fuel tank		76 l
Noise to environment (LwA)		< 106 dB
Vibration on hands/arms		< 0.50 m/s ²
Standards compliance		
This machine is in compliance with:		European directives: 2006/42/EC- Machinery (revised EN280:2013) - 2004/108/EC (EMC) - 2006/95/EC (Low voltage)

*Varies according to options and standards of the country to which the machine is delivered

** According to "REDUCE cycle"

280 TJ ST5 - Diagramas de carga

Load Chart for MEWP Metric

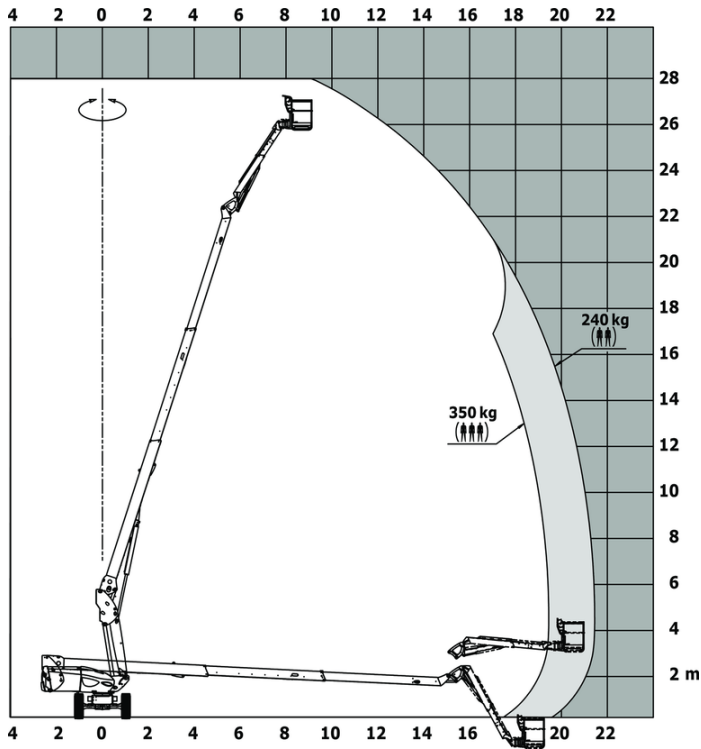

280 TJ ST5 - Diagrama dimensional



Equipamiento

Estándar

230V Predisposition
4 simultaneous movements
4 wheel drive
4 wheel steer with crab mode
Audible alarm and illuminated indicator lamp (leveling, overload, lowering)
Backup electrical pump
CAN bus technology
Connected machine
Continuous turret rotation
Dead man pedal
Differential locking on rear axle
Emergency stop button in platform and on frame
Engine on swivel chair
Engine with DPF (Diesel Particulate Filter)
Front axle with limited slip
Fuel gauge with low level indicator
Heavy-duty painted basket 2.30 m
Hom in the platform
Hour meter
LED rotating beacon
Large basket with three entries
Oscillating front axle
Remote control for transport
Stop & Go system
Telescopic jib
Turret orientation information
X Y function

Opcional

Additional storage boxes
Battery blanket
Battery cut-off
Biodegradable hydraulic oil - Grade 32
Cold weather protection oil
Easy link with remote lock
Engine Block Heater
High capacity starting battery
Hydraulic oil heater
Large basket 2.30m with lateral door
Lockable fuel cap
Non marking solid tyres
On-board generator (3,5 or 5 kW)
Painted narrow basket for heavy loads 1800mm (5 ft 11 in.)
Panel cradle
Personalized paintwork
Pipe cradle
Safety kit - Harness + helmet
Safety valve
Screen protection on the lower box control
Secondary Protection System (SPS)
Socket 230 V + differential circuit breaker
Spark arrester
Working light



 **MANITOU**
HANDLING YOUR WORLD

Oficina Central

B.P. 249 - 430 rue de l'Aubinière

44150 Ancenis Cedex - Francia

Tel.: 00 33 (0)2 40 09 10 11 - Fax: 00 33 (0)2 40 09 10 97

www.manitou.com



Esta publicación describe las versiones y posibilidades de configuración de los productos Manitou que puedan diferir en equipamiento. Los equipamientos presentados en este folleto pueden ser de serie, opcionales o no estar disponibles en algunas versiones. Manitou se reserva el derecho, en cualquier momento y sin previo aviso, de modificar las especificaciones descritas y representadas. Las especificaciones aportadas no comprometen al fabricante. Para más información, póngase en contacto con su concesionario Manitou. Documento no contractual. Presentación de los productos no contractual. Lista de especificaciones no exhaustiva. Los logos y la identidad visual de la empresa son propiedad de Manitou y no pueden ser utilizados sin autorización. Todos los derechos reservados. Las fotos y los esquemas contenidos en este folleto se ofrecen para consulta y a título indicativo solamente.

Manitou BF SA - Sociedad anónima con Consejo de Administración - Capital social: 39 668 399 euros - 857 802 508 RCS Nantes