

Ficha técnica :

100 SC



 **MANITOU**
HANDLING YOUR WORLD

| Capacities | | Métrico |
|--|---------|--|
| Working height | h21 | 9.70 m |
| Platform height | h7 | 7.70 m |
| Platform capacity | Q | 680 kg |
| Max. capacity on the extension deck | | 136 kg |
| Number of people (indoor / outdoor) | | 4 / 4 |
| Weight and dimensions | | |
| Platform weight* | | 3653 kg |
| Platform dimensions (length x width) | lp / ep | 2.79 m x 1.60 m |
| Platform dimensions with extension (length x width) | | 4.31 m x 1.60 m |
| Overall length | l1 | 3.76 m |
| Overall width | b1 | 1.75 m |
| Overall height | h17 | 2.59 m |
| Overall height (stowed) | h18 *** | 1.92 m |
| Overall length with platform extension | l15 | 4.81 m |
| External turning radius | Wa3 | 4.60 m |
| Ground clearance at centre of wheelbase | m2 | 0.24 m |
| Wheelbase | y | 2.29 m |
| Performances | | |
| Drive speed - stowed | | 5.60 km/h |
| Drive speed - raised | | 0.40 km/h |
| Raise speed (laden) / Lower speed (laden) | | 36 s / 33 s |
| Gradeability | | 35 % |
| Max outrigger leveling front uphill / back uphill | | 5.30 ° / 4.20 ° |
| Max outrigger leveling side to side | | 11.70 ° |
| Indoor and outdoor max Tilt Rating (Fore and Aft / Side-to-Side) | | 3 ° / 2 ° |
| Wheels | | |
| Tires type | | Foam-filled |
| Drive wheels (front / rear) | | 2 / 2 |
| Steering wheels (front / rear) | | 2 / 0 |
| Braking wheels (front / rear) | | 2 / 2 |
| Engine/Battery | | |
| Electric engine power rating | | 2 x 18.50 kW |
| Engine brand / model | | Kubota - D1105 |
| Engine nom | | Tier 4 final |
| I.C. Engine power rating | | 25 Hp |
| Miscellaneous | | |
| Ground Pressure | | 5.14 dan/cm2 |
| Hydraulic tank capacity | | 68.10 l |
| Fuel tank | | 37.90 l |
| Sound pressure level (ground workstation) | | 85 dB |
| Sound pressure level (platform work station) (platform work station) | | 79 dB |
| Vibration on hands/arms | | < 2.50 m/s ² |
| Standards compliance | | |
| This machine is in compliance with: | | European directives: 2006/42/EC- Machinery (revised EN280:2013) - 2004/108/EC (EMC) - 2006/95/EC (Low voltage) |

*Varies according to options and standards of the country to which the machine is delivered

*** With folded guardrail

100 SC - Diagramas de carga



100 SC - Diagrama dimensional

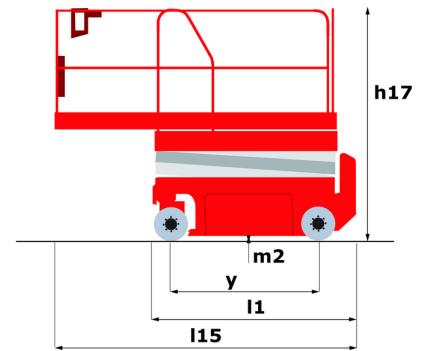
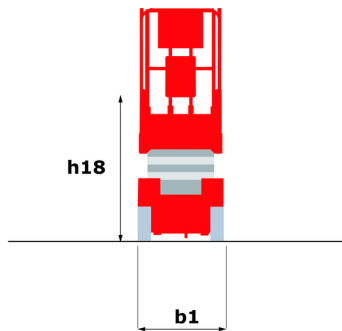
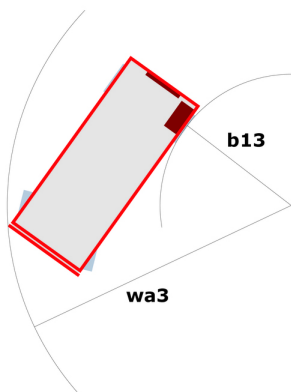

Equipamiento

Estándar

230V Predisposition

4 wheel drive

Anti-slip platform surface

Audible alarm and illuminated indicator lamp (leveling, overload, lowering)

CAN bus technology

Emergency stop button in platform and on frame

Engine mounted on sliding platform

Fixed anti-shearing protection

Fold away guard rails with full height swing gate

Hom in the platform

Hour meter

Integrated diagnostic assistance

Lowering alarm

Oscillating front axle

Platform access gate

Proportional controls

Removable control unit

Stabilizers with automatic leveling

Travel possible at maximum height

Opcional

2 flashing lights on frame

Biodegradable oil

Lights

Non-marking tyres

Safety harness

Working headlight in platform



Oficina Central

B.P. 249 - 430 rue de l'Aubinière

44150 Ancenis Cedex - Francia

Tel.: 00 33 (0)2 40 09 10 11 - Fax: 00 33 (0)2 40 09 10 97

www.manitou.com



Esta publicación describe las versiones y posibilidades de configuración de los productos Manitou que puedan diferir en equipamiento. Los equipamientos presentados en este folleto pueden ser de serie, opcionales o no estar disponibles en algunas versiones. Manitou se reserva el derecho, en cualquier momento y sin previo aviso, de modificar las especificaciones descritas y representadas. Las especificaciones aportadas no comprometen al fabricante. Para más información, póngase en contacto con su concesionario Manitou. Documento no contractual. Presentación de los productos no contractual. Lista de especificaciones no exhaustiva. Los logos y la identidad visual de la empresa son propiedad de Manitou y no pueden ser utilizados sin autorización. Todos los derechos reservados. Las fotos y los esquemas contenidos en este folleto se ofrecen para consulta y a título indicativo solamente.

Manitou BF SA - Sociedad anónima con Consejo de Administración - Capital social: 39 668 399 euros - 857 802 508 RCS Nantes