

Fiche technique :

MI-X 50 L D



 **MANITOU**
HANDLING YOUR WORLD

Technical characteristics			Métrique
1.1	Manufacturer		Manitou
1.2	Model Name		MI-X 50 L D
1.3	Power source		Diesel
1.4	Operator type		Seated
1.5	Max. capacity	Q	5000 kg
1.6	Load center of gravity	c	600 mm
1.8	Load distance, centre of drive axle to fork	x	598 mm
1.9	Wheelbase	y	2300 mm
Weight			
2.1	Service weight		8295 kg
2.2	Weight on front axle (laden) / rear axle (laden)		11500 kg / 1795 kg
2.3	Weight on front axle (Unladen) / rear axle (Unladen)		4080 kg / 4215 kg
Wheels			
3.1	Tires type		Pneumatic
3.2	Dimensions of front wheels		8.25-15-14PR
3.3	Dimensions of rear wheels		8.25-15-14PR
3.5	Number of front wheels / rear wheels		4 / 2
3.5.2	Number of drive wheels		4
3.6	Front wheel gauge	b10	1489 mm
3.7	Rear wheel gauge	b11	1700 mm
Dimensions			
4.7	Height of overhead guard (cabin)	h6	2430 mm
4.8	Seat height/stand height	h7	1350 mm
4.12	Height of towing bar (coupling height)	h10	710 mm
4.19	Overall length	l1	4719 mm
4.20	Length to face of forks	l2	3499 mm
4.21	Overall width	b1	1990 mm
4.21	Overall width - Single wheels	b1	1990 mm
4.22	Forks section / width / length	s / e / l	60 mm x 150 mm x 1220 mm
4.23	Fork carriage ISO 2328 (class/form) A/B		4A
4.24	Fork carriage width	b3	1700 mm
4.31	Ground clearance below mast	m1	190 mm
4.32	Ground clearance at centre of wheelbase	m2	270 mm
4.33	Aisle Width for pallets 1000 x 1200 crossways	Ast	5137 mm
4.34	Aisle width for 800 x 1200 pallet lengthways	Ast	5272 mm
4.35	Turning radius	Wa	3230 mm
4.36	Internal turning radius (over tyres)	b13	1222 mm
Performances			
5.1	Travel speed (laden / unladen)		27 km/h-29 km/h
5.2	Lifting speed (laden / unladen)		0.47 m/s-0.49 m/s
5.3	Lowering speed (laden / unladen)		0.48 m/s-0.42 m/s
5.5	Drawbar pull (Laden / Unladen)		6500 daN / 2544 daN
5.7	Gradeability (laden)		48 %
5.10	Service brake		Hydraulic
Engine			
7.1	Engine brand / model		Cummins / QSB3,3
7.2	I.C. Engine power rating		74 kW
7.3	Rated speed		2200 rpm
7.4	Number of cylinders / Capacity of cylinders		4 - 3300 cm ³
Miscellaneous			
8.2	Working hydraulic pressure for attachments		195 bar
8.3	Oil flow rate for attachments		55 l/min
8.4	Measured/guaranteed mean noise level at the ear of the operator		< 84 dB
8.4	Sound level at the driver's ear according to DIN 12 053		84 dB

MI-X 50 L D - Schémas d'encombrement

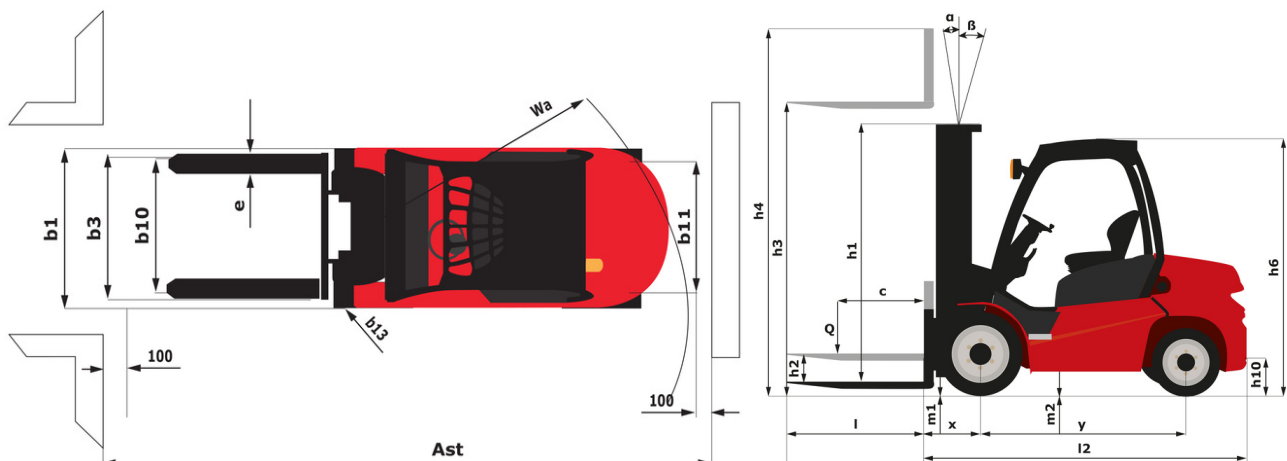

Caractéristiques des mâts et capacités résiduelles

Full Visibility Duplex (FVD)	FVD 30	FVD 33	FVD 36	FVD 40	FVD 45	FVD 50
α - Mast/fork carriage tilt, forward	°	6	6	6	6	6
β - Mast/fork carriage tilt, backward	°	12	12	12	12	6
h1 - Mast lowered height	mm	2500	2650	2800	3000	3300
h2 - Mast free lift	mm	160	160	160	160	160
h3 - Mast lifting height	mm	3000	3300	3600	4000	4500
h4 - Mast extended height	mm	3995	4295	4595	5167	5500
Residual capacity at max height	kg	5000	5000	5000	5000	5000
Residual capacity with hooked-on side shift at max height	kg	4500	4500	4500	4500	4500
Height at max capacity	mm	3000	3300	3600	4000	4500
Height at max capacity with hooked-on sideshift	mm	3000	3300	3600	4000	4500

Free Lift Duplex (FLD)	FLD 30	FLD 33	FLD 36	FLD 40
α - Mast/fork carriage tilt, forward	°	6	6	6
β - Mast/fork carriage tilt, backward	°	12	12	12
h1 - Mast lowered height	mm	2450	2600	2750
h2 - Mast free lift	mm	1495	1645	1795
h3 - Mast lifting height	mm	3000	3300	3600
h4 - Mast extended height	mm	3955	4255	4555
Residual capacity at max height	kg	5000	5000	5000
Residual capacity with integrated side shift at max height	kg	4500		
Residual capacity with hooked-on side shift at max height	kg		4500	4500
Height at max capacity	mm	3000	3300	3600
Height at max capacity with hooked-on sideshift	mm	3000	3300	3600

Free Lift Triplex (FLT)	FLT 45	FLT 48	FLT 50	FLT 55	FLT 60
α - Mast/fork carriage tilt, forward	°	6	6	6	3
β - Mast/fork carriage tilt, backward	°	6	6	6	6
h1 - Mast lowered height	mm	2.73	2825	2875	3075
h2 - Mast free lift	mm	1500	1600	1672	1800
h3 - Mast lifting height	mm	4500	4800	5000	5500
h4 - Mast extended height	mm	5735	6035	6213	6785
Residual capacity at max height	kg	4500	4500	4500	4200
Residual capacity with hooked-on side shift at max height	kg	4000	4000	4000	3700
Height at max capacity	mm	4500	4800	5000	5500
Height at max capacity with hooked-on sideshift	mm	4500	4800	5000	5500



Siège Social

B.P. 249 - 430 rue de l'Aubinière

44150 Ancenis Cedex - France

Tel: +33 (0)2 40 09 10 11 - Fax: +33 (0)2 40 09 10 97

www.manitou.com



Cette publication présente le descriptif des versions et possibilités de configuration des produits Manitou qui peuvent différer en équipement. Les équipements présentés dans cette brochure peuvent être de série, en option, ou non disponibles suivant les versions. Manitou se réserve le droit, à tout moment et sans préavis, de modifier les spécifications décrites et représentées. Les spécifications portées n'engagent pas le constructeur. Pour plus de détails, contactez votre concessionnaire Manitou. Document non contractuel. Présentation des produits non contractuelle. Liste des spécifications non exhaustive. Les logos ainsi que l'identité visuelle de l'entreprise sont la propriété de Manitou et ne peuvent être utilisés sans autorisation. Tous droits réservés. Les photos et schémas contenus dans la présente brochure ne sont fournis qu'à des fins de consultation et à titre indicatif.

Manitou BF SA - Société anonyme à conseil d'administration - Capital social : 39 668 399 euros - 857 802 508 RCS Nantes