

Technical sheet :

90 V'AIR

OXYGEN
by MANITOU



 **MANITOU**
HANDLING YOUR WORLD

Capacities		Metric
Working height	h21	9 m
Platform height	h7	7 m
Max. outreach		2.04 m
Platform capacity	Q	230 kg
Turret rotation		350 °
Number of people (indoor / outdoor)		2 / 2
Weight and dimensions		
Platform weight*		2710 kg
Platform dimensions (length x width)	lp / ep	0.95 m x 0.68 m
Floor height (access)	h20	1.03 m
Overall length	l1	2.31 m
Overall width	b1	1.10 m
Overall height	h17	2.31 m
Counterweight offset (turret at 90°)	a7	0.04 m
Counterweight Oversize / Reach		0.05 m
External turning radius	Wa3	1.98 m
Ground clearance at centre of wheelbase	m2	0.09 m
Wheelbase	y	1.20 m
Performances		
Drive speed - stowed		4.50 km/h
Drive speed - raised		0.60 km/h
Gradeability		25 %
Permissible leveling		2 °
Wheels		
Tires type		Non marking
Standard tires		406 x 127 mm
Drive wheels (front / rear)		0 / 2
Steering wheels (front / rear)		2 / 0
Braking wheels (front / rear)		0 / 2
Engine/Battery		
Electric engine power rating		2 x 1.50 kW
Number of hydraulic pump / Capacity of hydraulic pump		2 x 4.20 cm ³
Battery voltage		24 V
Battery capacity		250 Ah
On-board charger (V / A)		24 V / 30 A
Miscellaneous		
Number of cycles with STD Battery (HIRD)		39
Ground Pressure		11.30 dan/cm ²
Hydraulic Pressure		140 bar
Hydraulic tank capacity		22 l
Standards compliance		
This machine is in compliance with:		European directives: 2006/42/EC- Machinery (revised EN280:2013) - 2004/108/EC (EMC) - 2006/95/EC (Low voltage)

90 V'Air - Load chart

Load Chart for MEWP Metric

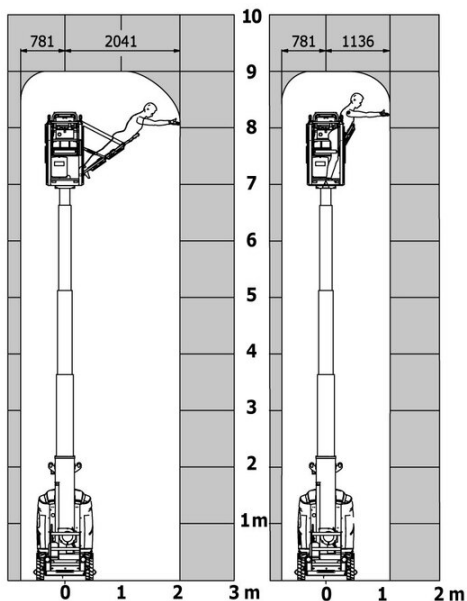

90 V'Air - Dimensional drawing

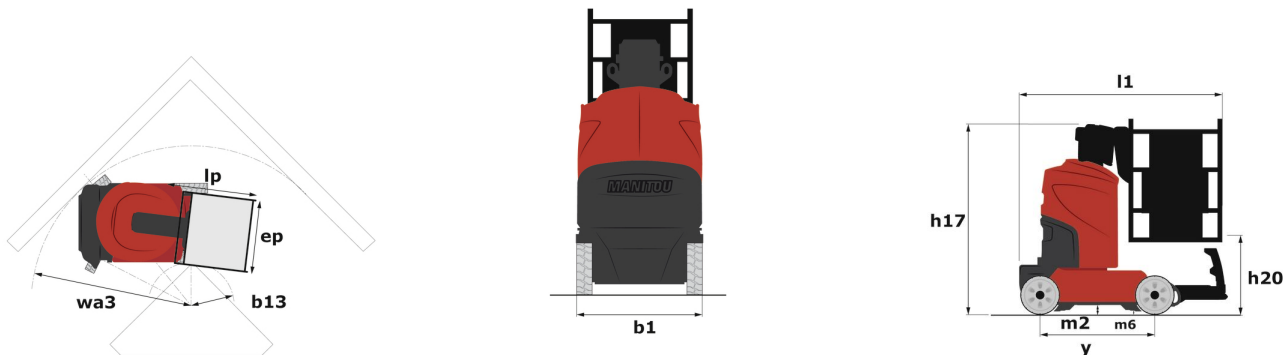

Equipment

Standard
2 LED front headlights with protective grille
2 rear position headlights with LED
2 vertical detection radars
3 anti-static braids
Audible alarm and illuminated indicator lamp (leveling, overload, lowering)
Backlit control panel
Battery charge indicator lamp
CAN bus technology
Emergency stop button in platform and on frame
Fixed pothole protection
Front and side rubber protections
Hom in the platform
Hour meter
Integrated diagnostic assistance
Manual emergency lowering
Multi-voltage integrated charger
Negative-type braking on rear wheels
Non-marking rubber tyres
Platform with open-work floor
Proportional controls
Side reflectors
Slings and securing rings
Specific platform with multiple working positions
Tool box in platform
Traction battery with centralized recharging
Travel possible at maximum height
Working headlight in platform

Optional
6 kg Powder extinguisher A, B, C
Biodegradable oil
Cold weather protection oil
Safety kit - Harness + helmet



 **MANITOU**
HANDLING YOUR WORLD

Head Office

B.P. 249 - 430 rue de l'Aubinière
44150 Ancenis Cedex - France

Tel: +33 (0)2 40 09 10 11 - Fax: +33 (0)2 40 09 10 97

www.manitou.com



This publication provides a description of the configuration versions and options for Manitou products, which may differ for equipment. The equipment presented in this brochure may be part of a series, as an option, or it may not be available, depending on the versions. Manitou reserves the right, at any time and without notice, to amend the specifications described and represented. The specifications provided do not bind the manufacturer. For more details, please contact your Manitou agent. This is not a contractually binding document. The presentation of the products is not contractually binding. List of specifications non-exhaustive. The logos as well as the visual identity of the company are owned by Manitou and cannot be used without authorisation. All rights reserved. The photos and diagrams contained in this brochure are only provided for consultation and information purposes.

MANITOU BF SA - Limited company with board of directors - Share capital: 39,668,399 euros - 857 802 508 RCS Nantes