

Ficha técnica :

90 V'AIR

OXYGEN
by MANITOU



 **MANITOU**
HANDLING YOUR WORLD

Capacities		Métrico
Working height	h21	9 m
Platform height	h7	7 m
Max. outreach		2.04 m
Platform capacity	Q	230 kg
Turret rotation		350 °
Number of people (indoor / outdoor)		2 / 2
Weight and dimensions		
Platform weight*		2710 kg
Platform dimensions (length x width)	lp / ep	0.95 m x 0.68 m
Floor height (access)	h20	1.03 m
Overall length	l1	2.31 m
Overall width	b1	1.10 m
Overall height	h17	2.31 m
Counterweight offset (turret at 90°)	a7	0.04 m
Counterweight Oversize / Reach		0.05 m
External turning radius	Wa3	1.98 m
Ground clearance at centre of wheelbase	m2	0.09 m
Wheelbase	y	1.20 m
Performances		
Drive speed - stowed		4.50 km/h
Drive speed - raised		0.60 km/h
Gradeability		25 %
Permissible leveling		2 °
Wheels		
Tires type		Non marking
Standard tires		406 x 127 mm
Drive wheels (front / rear)		0 / 2
Steering wheels (front / rear)		2 / 0
Braking wheels (front / rear)		0 / 2
Engine/Battery		
Electric engine power rating		2 x 1.50 kW
Number of hydraulic pump / Capacity of hydraulic pump		2 x 4.20 cm ³
Battery voltage		24 V
Battery capacity		250 Ah
On-board charger (V / A)		24 V / 30 A
Miscellaneous		
Number of cycles with STD Battery (HIRD)		39
Ground Pressure		11.30 dan/cm ²
Hydraulic Pressure		140 bar
Hydraulic tank capacity		22 l
Standards compliance		
This machine is in compliance with:		European directives: 2006/42/EC- Machinery (revised EN280:2013) - 2004/108/EC (EMC) - 2006/95/EC (Low voltage)

90 V'Air - Diagramas de carga

Load Chart for MEWP Metric

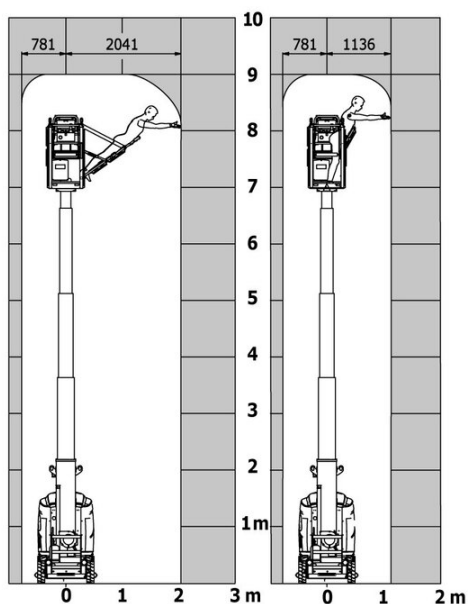

90 V'Air - Diagrama dimensional

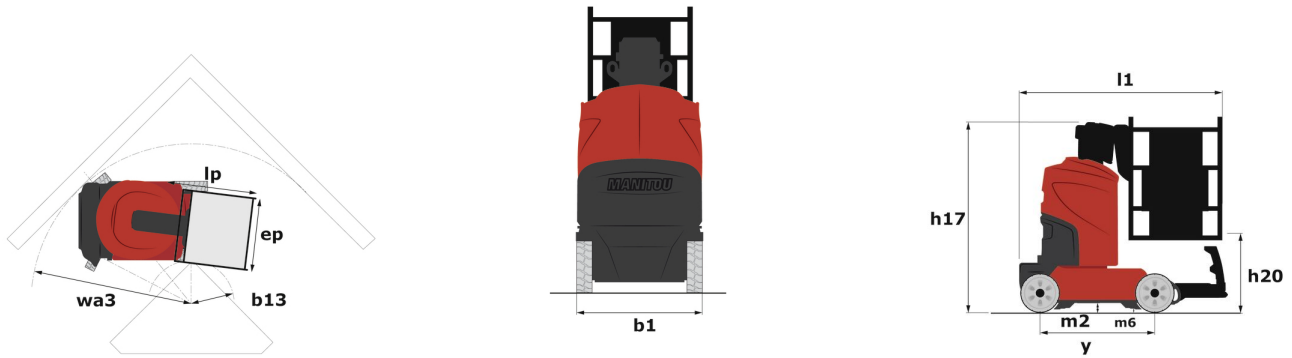

Equipamiento

Estándar

2 LED front headlights with protective grille

2 rear position headlights with LED

2 vertical detection radars

3 anti-static braids

Audible alarm and illuminated indicator lamp (leveling, overload, lowering)

Backlit control panel

Battery charge indicator lamp

CAN bus technology

Emergency stop button in platform and on frame

Fixed pothole protection

Front and side rubber protections

Hour in the platform

Hour meter

Integrated diagnostic assistance

Manual emergency lowering

Multi-voltage integrated charger

Negative-type braking on rear wheels

Non-marking rubber tyres

Platform with open-work floor

Proportional controls

Side reflectors

Slings and securing rings

Specific platform with multiple working positions

Tool box in platform

Traction battery with centralized recharging

Travel possible at maximum height

Working headlight in platform

Opcional

6 kg Powder extinguisher A, B, C

Biodegradable oil

Cold weather protection oil

Safety kit - Harness + helmet



Oficina Central

B.P. 249 - 430 rue de l'Aubinière

44150 Ancenis Cedex - Francia

Tel.: 00 33 (0)2 40 09 10 11 - Fax: 00 33 (0)2 40 09 10 97

www.manitou.com



Esta publicación describe las versiones y posibilidades de configuración de los productos Manitou que puedan diferir en equipamiento. Los equipamientos presentados en este folleto pueden ser de serie, opcionales o no estar disponibles en algunas versiones. Manitou se reserva el derecho, en cualquier momento y sin previo aviso, de modificar las especificaciones descritas y representadas. Las especificaciones aportadas no comprometen al fabricante. Para más información, póngase en contacto con su concesionario Manitou. Documento no contractual. Presentación de los productos no contractual. Lista de especificaciones no exhaustiva. Los logos y la identidad visual de la empresa son propiedad de Manitou y no pueden ser utilizados sin autorización. Todos los derechos reservados. Las fotos y los esquemas contenidos en este folleto se ofrecen para consulta y a título indicativo solamente.

Manitou BF SA - Sociedad anónima con Consejo de Administración - Capital social: 39 668 399 euros - 857 802 508 RCS Nantes