

Technical sheet :

ME 418



 **MANITOU**
HANDLING YOUR WORLD

Technical characteristics		Metric	
1.1	Manufacturer		Manitou
1.2	Model Name		ME 418
1.3	Power source		Electrical - Lead
1.4	Operator type		Seated
1.5	Max. capacity	Q	1800 kg
1.6	Load center of gravity	c	500 mm
1.8	Load distance, centre of drive axle to fork	x	411 mm
1.9	Wheelbase	y	1380 mm
Weight			
2.1	Service weight		3070 kg
2.2	Weight on front axle (laden) / rear axle (laden)		4350 kg / 520 kg
2.3	Weight on front axle (Unladen) / rear axle (Unladen)		1400 kg / 1670 kg
Wheels			
3.1	Tires type		Solid tires
3.2	Dimensions of front wheels		21 x 8-9
3.3	Dimensions of rear wheels		5.00-8
3.5	Number of front wheels / rear wheels		2 / 2
3.5.2	Number of drive wheels		2
3.6	Front wheel gauge	b10	938 mm
3.7	Rear wheel gauge	b11	898 mm
Dimensions			
4.8	Seat height/stand height	h7	1045 mm
4.7	Height of overhead guard (cabin)	h6	2130 mm
4.12	Height of towing bar (coupling height)	h10	275 mm
4.19	Overall length	l1	3248 mm
4.20	Length to face of forks	l2	2098 mm
4.21	Overall width	b1	1138 mm
4.22	Forks section / width / length	s / e / l	100 mm x 1150 mm x 35 mm
4.23	Fork carriage ISO 2328 (class/form) A/B		2A
4.24	Fork carriage width	b3	1000 mm
4.31	Ground clearance below mast	m1	100 mm
4.32	Ground clearance at centre of wheelbase	m2	110 mm
4.33	Aisle Width for pallets 1000 x 1200 crossways	Ast	3511 mm
4.34	Aisle width for 800 x 1200 pallet lengthways	Ast	3711 mm
4.35	Turning radius	Wa	1900 mm
4.36	Internal turning radius (over tyres)	b13	680 mm
Performances			
5.1	Travel speed (laden / unladen)		13.50 km/h-14 km/h
5.2	Lifting speed (laden / unladen)		0.29 m/s-0.44 m/s
5.3	Lowering speed (laden / unladen)		0.49 m/s-0.48 m/s
5.5	Drawbar pull (Laden / Unladen)		1200 daN / 1100 daN
5.7	Gradeability (laden / unladen)		12 % / 13 %
5.10	Service brake		Hydraulic
Engine			
6.1	Drive motor rating S2 60 min		8 kW
6.2	Lift motor rating at S3 15%		8.60 kW
6.3	Battery according to DIN 43531/35/36 A, B, C		DIN43531 A
6.4	Battery voltage / capacity		48 V / 465 Ah
6.6	Energy consumption according to VDI cycle (kWh/h)		4.60 kWh/h
Miscellaneous			
8.1	Type of drive control		Electronic
8.2	Working hydraulic pressure for attachments		175 bar
8.3	Oil flow rate for attachments		35 l/min
8.4	Measured/guaranteed mean noise level at the ear of the operator		< 71 dB
8.4	Sound level at the driver's ear according to DIN 12 053		71 dB

ME 418 - Dimensional drawing

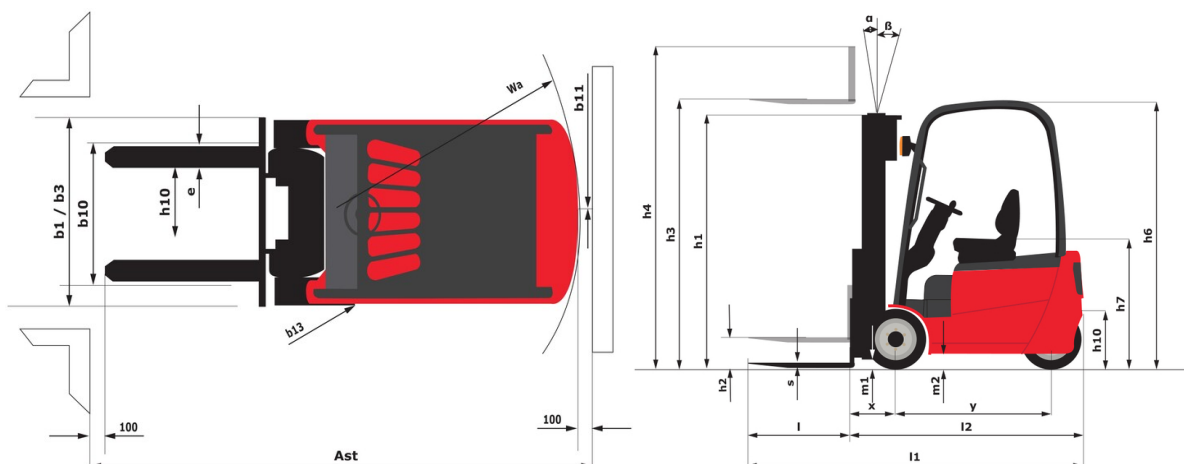

**Head Office**

B.P. 249 - 430 rue de l'Aubinière
44150 Ancenis Cedex - France

Tel: +33 (0)2 40 09 10 11 - Fax: +33 (0)2 40 09 10 97

www.manitou.com



This publication provides a description of the configuration versions and options for Manitou products, which may differ for equipment. The equipment presented in this brochure may be part of a series, as an option, or it may not be available, depending on the versions. Manitou reserves the right, at any time and without notice, to amend the specifications described and represented. The specifications provided do not bind the manufacturer. For more details, please contact your Manitou agent. This is not a contractually binding document. The presentation of the products is not contractually binding. List of specifications non-exhaustive. The logos as well as the visual identity of the company are owned by Manitou and cannot be used without authorisation. All rights reserved. The photos and diagrams contained in this brochure are only provided for consultation and information purposes.

MANITOU BF SA - Limited company with board of directors - Share capital: 39,668,399 euros - 857 802 508 RCS Nantes