

Technical sheet :

ME 315 C



 **MANITOU**
HANDLING YOUR WORLD

Technical characteristics		Metric	
1.1	Manufacturer		Manitou
1.2	Model Name		ME 315c
1.3	Power source		Electrical
1.4	Operator type		Seated
1.5	Max. capacity	Q	1500 kg
1.6	Load center of gravity	c	500 mm
1.8	Load distance, centre of drive axle to fork	x	365 mm
1.9	Wheelbase	y	1220 mm
Weight			
2.1	Service weight		3000 kg
2.2	Weight on front axle (laden) / rear axle (laden)		3930 kg / 570 kg
2.3	Weight on front axle (Unladen) / rear axle (Unladen)		1370 kg / 1630 kg
Wheels			
3.1	Tires type		Super Elastic
3.2	Dimensions of front wheels		18x7-8
3.3	Dimensions of rear wheels		200/50-10
3.5	Number of front wheels / rear wheels		2 / 1
3.5.2	Number of drive wheels		1
3.6	Front wheel gauge	b10	835 mm
Dimensions			
4.7	Height of overhead guard (cabin)	h6	2105 mm
4.8	Seat height/stand height	h7	1020 mm
4.12	Height of towing bar (coupling height)	h10	500 mm
4.19	Overall length	l1	3015 mm
4.20	Length to face of forks	l2	1865 mm
4.21	Overall width	b1	990 mm
4.22	Forks section / width / length	s / e / l	35 mm x 100 mm x 1150 mm
4.23	Fork carriage ISO 2328 (class/form) A/B		2A
4.24	Fork carriage width	b3	1000 mm
4.31	Ground clearance below mast	m1	100 mm
4.32	Ground clearance at centre of wheelbase	m2	100 mm
4.33	Aisle Width for pallets 1000 x 1200 crossways	Ast	3201 mm
4.34	Aisle width for 800 x 1200 pallet lengthways	Ast	3325 mm
4.35	Turning radius	Wa	1510 mm
Performances			
5.1	Travel speed (laden / unladen)		9.50 km/h/10.50 km/h
5.2	Lifting speed (laden / unladen)		0.22 m/s-0.34 m/s
5.3	Lowering speed (laden / unladen)		0.58 m/s-0.48 m/s
5.5	Drawbar pull (Laden / Unladen)		500 daN / 530 daN
5.7	Gradeability (laden / unladen)		7 % / 9 %
5.10	Service brake		Hydraulic
Engine			
6.1	Drive motor rating S2 60 min		4 kW
6.3	Battery according to DIN 43531/35/36 A, B, C		DIN43535 A
6.4	Battery voltage / capacity		24 V / 840 Ah
7.2	I.C. Engine power rating		8.60 kW
6.6	Energy consumption according to VDI cycle (kWh/h)		3.50 kWh
Miscellaneous			
8.1	Type of drive control		Electric
8.2	Working hydraulic pressure for attachments		145 bar
8.3	Oil flow rate for attachments		16 l/min
8.4	Measured/guaranteed mean noise level at the ear of the operator		< 70 dB
8.4	Sound level at the driver's ear according to DIN 12 053		40 dB

ME 315 C - Dimensional drawing

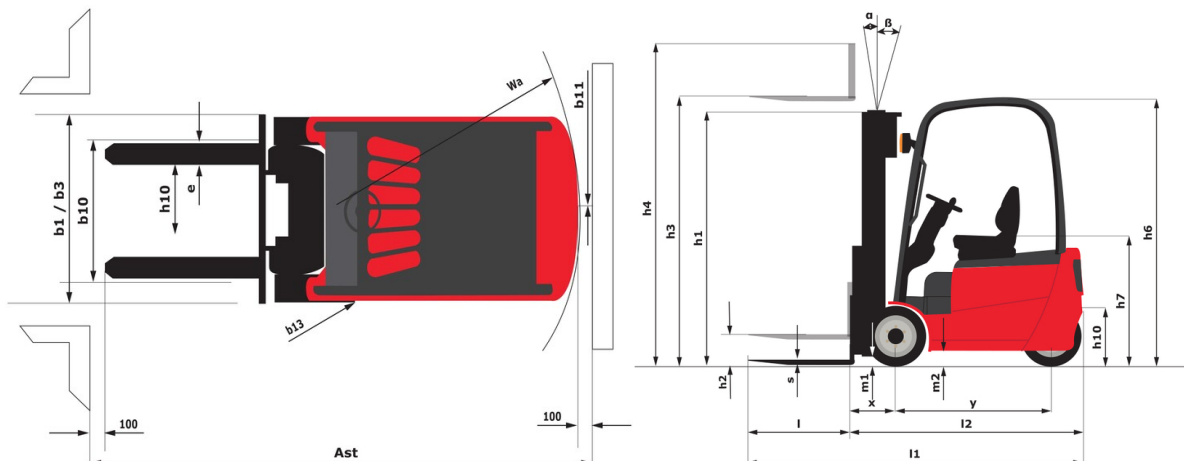



Head Office

B.P. 249 - 430 rue de l'Aubinière

44150 Ancenis Cedex - France

Tel: +33 (0)2 40 09 10 11 - Fax: +33 (0)2 40 09 10 97

www.manitou.com



This publication provides a description of the configuration versions and options for Manitou products, which may differ for equipment. The equipment presented in this brochure may be part of a series, as an option, or it may not be available, depending on the versions. Manitou reserves the right, at any time and without notice, to amend the specifications described and represented. The specifications provided do not bind the manufacturer. For more details, please contact your Manitou agent. This is not a contractually binding document. The presentation of the products is not contractually binding. List of specifications non-exhaustive. The logos as well as the visual identity of the company are owned by Manitou and cannot be used without authorisation. All rights reserved. The photos and diagrams contained in this brochure are only provided for consultation and information purposes.

MANITOU BF SA - Limited company with board of directors - Share capital: 39,668,399 euros - 857 802 508 RCS Nantes