

Technical sheet :

MSI 25 ST5



	Technical characteristics		Imperial
1.1	Manufacturer		Manitou
1.2	Model Name		MSI 25 ST5
1.3	Power source		Diesel
1.4	Operator type		Seated
1.5	Max. capacity	Q	5512 lb
1.6	Load center of gravity	c	20 in
1.8	Load distance, centre of drive axle to fork	x	24 in
1.9	Wheelbase	y	75 in
	Standard mast reference of the machine		FVD 33
Weight			
2.1	Service weight		8598 lb
2.2	Weight on front axle (laden) / rear axle (laden)		12632 lb / 1477 lb
2.3	Weight on front axle (Unladen) / rear axle (Unladen)		3505 lb / 5093 lb
Wheels			
3.1	Tires type		Pneumatic
3.2	Dimensions of front wheels		300-15/18 6T P43
3.3	Dimensions of rear wheels		7.00-12/12 ED PLUS
3.5	Number of front wheels / rear wheels		2 / 2
3.5.2	Number of drive wheels		2
3.6	Front wheel gauge	b10	41 in
3.7	Rear wheel gauge	b11	44 in
Dimensions			
4.7	Height of overhead guard (cabin)	h6	82 in
4.8	Seat height/stand height	h7	38 in
4.19	Overall length	l1	165 in
4.20	Length to face of forks	l2	118 in
4.21	Overall width	b1	52 in
4.22	Forks section / width / length	s / e / l	2 in x 4 in x 47 in
4.23	Fork carriage ISO 2328 (class/form) A/B		2A
4.24	Fork carriage width	b3	50 in
4.31	Ground clearance below mast	m1	10 in
4.32	Ground clearance at centre of wheelbase	m2	9 in
4.33	Aisle Width for pallets 1000 x 1200 crossways	Ast	183 in
4.35	Turning radius	Wa	103 in
Performances			
5.1	Travel speed (laden / unladen)		13 mph-13 mph
5.2	Lifting speed (laden / unladen)		2 ft/s-2 ft/s
5.3	Lowering speed (laden / unladen)		2 ft/s-0.98 ft/s
5.5	Drawbar pull (Laden)		1900 daN
5.7	Gradeability (laden)		31 %
5.10	Service brake		Hydraulic brakes by loss of pressure
	Transmission type		Hydrostatic
Engine			
7.1	Engine brand / model / norm		Kubota / D1803 CRT E5B / Stage V
7.2	I.C. Engine power rating		37 kW
7.3	Rated speed		2700 rpm
7.4	Number of cylinders / Capacity of cylinders		3 - 111 in³
Miscellaneous			
8.1	Type of drive control		Electronic
8.2	Working hydraulic pressure for attachments		3191 PSI
8.3	Oil flow rate for attachments		12 US gpm
8.4	Sound level at the driver's ear according to DIN 12 053		81 dB

MSI 25 ST5 - Dimensional drawing

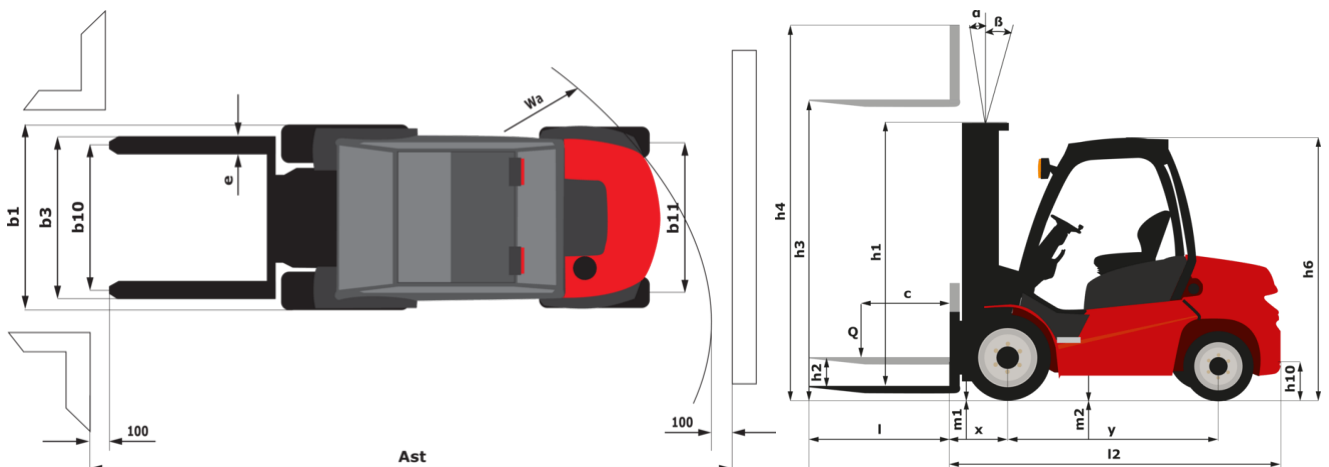

Characteristics of masts and residual capacities

Full Visibility Duplex (FVD)	FVD 30	FVD 33	FVD 37	FVD 40	FVD 45
α - Mast/fork carriage tilt, forward	°	12	12	12	12
β - Mast/fork carriage tilt, backward	°	10	10	10	10
h1 - Mast lowered height	in	84.1	90	100.2	107.7
h2 - Mast free lift	in	3.3	3.3	3.3	3.3
h3 - Mast lifting height	in	118.1	129.9	145.7	157.5
h4 - Mast extended height	in	147.2	159	174.7	186.5
Residual capacity at max height	lb	5512	5512	5512	5512
Residual capacity with hooked-on side shift at max height	lb	5512	5512	5512	5512
Height at max capacity	in	118.1	129.9	145.7	157.5
Height at max capacity with hooked-on sideshift	in	118.1	129.9	145.7	157.5

Free Lift Triplex (FLT)	FLT 34	FLT 37	FLT 40	FLT 43	FLT 47	FLT 55	FLT 60
α - Mast/fork carriage tilt, forward	°	12	12	12	12	6	6
β - Mast/fork carriage tilt, backward	°	10	10	10	10	6	6
h1 - Mast lowered height	in	76.2	80.2	84.1	90	93.9	107.7
h2 - Mast free lift	in	46.6	50.5	54.4	58.4	64.3	74.5
h3 - Mast lifting height	in	133.9	145.7	157.5	169.3	185	216.5
h4 - Mast extended height	in	164.7	176.5	188.3	201.4	215.9	250.2
Residual capacity at max height	lb	5512	5512	5512	5512	5512	5071
Residual capacity with hooked-on side shift at max height	lb	5512	5512	5512	5512	5512	5071
Height at max capacity	in	133.9	145.7	157.5	169.3	185	204.7
Height at max capacity with hooked-on sideshift	in	133.9	145.7	157.5	169.3	185	204.7

Full Visibility Triplex (FVT)	FVT 33	
α - Mast/fork carriage tilt, forward	°	12
β - Mast/fork carriage tilt, backward	°	10
h1 - Mast lowered height	in	71.9
h2 - Mast free lift	in	2.8
h3 - Mast lifting height	in	129.9
h4 - Mast extended height	in	158.5
Height at max capacity	in	98.4



Head Office

B.P. 249 - 430 rue de l'Aubinière

44150 Ancenis Cedex - France

Tel: +33 (0)2 40 09 10 11 - Fax: +33 (0)2 40 09 10 97

www.manitou.com



This publication provides a description of the configuration versions and options for Manitou products, which may differ for equipment. The equipment presented in this brochure may be part of a series, as an option, or it may not be available, depending on the versions. Manitou reserves the right, at any time and without notice, to amend the specifications described and represented. The specifications provided do not bind the manufacturer. For more details, please contact your Manitou agent. This is not a contractually binding document. The presentation of the products is not contractually binding. List of specifications non-exhaustive. The logos as well as the visual identity of the company are owned by Manitou and cannot be used without authorisation. All rights reserved. The photos and diagrams contained in this brochure are only provided for consultation and information purposes.

MANITOU BF SA - Limited company with board of directors - Share capital: 39,668,399 euros - 857 802 508 RCS Nantes