

Technical sheet :

4200V



 **MANITOU**
HANDLING YOUR WORLD

Capacities		Metric
Rated Operating Capacity		1905 kg
Unladen weight		5291 kg
Weight and dimensions		
Wheelbase	y	1387 mm
Overall Operating Height - Fully Raised	h27	4745 mm
Height to Hinge Pin - Fully Raised	h28	3647 mm
Overall Height to top of ROPS	h17	2083 mm
Dump angle at full height	a5	31 °
Dump height	h29	2916 mm
Overall length with bucket	l16	4026 mm
Dump reach - Full height	r6	1003 mm
Rollback at ground	a13	31 °
Seat to ground height	h30	1046 mm
Overall width less bucket	b1	2019 mm
Bucket Width	e1	2134 mm
Ground clearance	m4	185 mm
Overall length - Less Bucket	l2	3086 mm
Departure angle	a2	19 °
Clearance Radius - Front with Bucket	b18	2248 mm
Performances		
Travel speed (unladen)		10.53 km/h
Travel Speed with Two-Speed Option - Maximum		18.70 km/h
Wheels		
Standard tires		14.00 x 17.5 HD
Engine		
Engine brand		Deutz
Engine model		TCD 3.6
Gross Power		74 kW
Net Power		97.20 kW
Max. torque / Engine rotation		442 Nm / 2200 rpm
Power source		Diesel
Battery voltage		12 V
Alternator		130 kW
Starter		2.30 kW
Hydraulics		
High-Flow Auxiliary Hydraulics - Option		154 l/min
Tank capacities		
Fuel tank		39.40 l
Hydraulic tank capacity		63.40 l
Displacement		3.60 l
Noise and vibration		
Noise to environment (LwA)		101 dB
Noise at driving position (LpA)		85 dB
Whole-Body Vibration (ISO 2631-1)		0.79 m/s ²
Vibration on hands/arms		< 1.20 m/s ²

4200V - Dimensional drawing

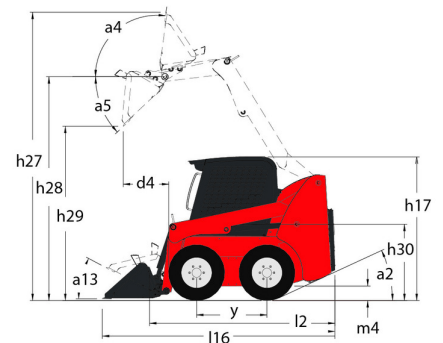
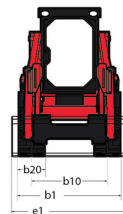
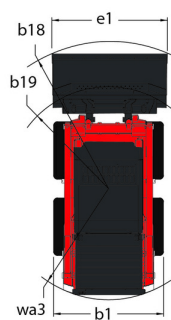

Equipment

—	
Integral Access Plate (removable)	Standard
Lifting function	
All-Tach® Attachment Mounting System	Standard
Auxiliary Hydraulics	Standard
High-Flow Auxiliary Hydraulics	Standard
Power-A-Tach® Attachment Mounting System	Standard
Lighting	
Work Lights - Front and Rear	Standard
Motorization/Power	
Engine Auto-Shutdown System	Standard
Engine Block Heater	Standard
Swing-Out Cooler	Standard
Turbo-Charged Engine	Standard
Two-Speed Drive	Standard
Operator station	
Adjustable Arm Rests / Control Towers 1	Standard
Air conditioning with manual adjustment	Standard
Air suspension seat	Standard
Cab Enclosure	Optional
Foot and Hand Throttles 2	Standard
Heating	Standard
High-Back Adjustable Seat	Standard
Hom	Standard
Joystick controls	Standard
ROPS/FOPS Level II Overhead Guard	Standard
Other options	
Hydrostatic Drive - Servo	Standard
Selectable Self-Leveling Hydraulic Lift Action 4	Standard
Secondary functions	
Full Instrumentation	Standard
Hydraglide™ Ride Control 3	Standard
Security	
Anti-Vandalism Protection	Standard
Back-Up Alarm	Standard
Brake Control (Auto / Manual)	Standard
Hyaloc™ Safety System	Standard
Lift Arm Support Device	Standard
Operator Restraint Bar	Standard



Head Office

B.P. 249 - 430 rue de l'Aubinière

44150 Ancenis Cedex - France

Tel: +33 (0)2 40 09 10 11 - Fax: +33 (0)2 40 09 10 97

www.manitou.com



This publication provides a description of the configuration versions and options for Manitou products, which may differ for equipment. The equipment presented in this brochure may be part of a series, as an option, or it may not be available, depending on the versions. Manitou reserves the right, at any time and without notice, to amend the specifications described and represented. The specifications provided do not bind the manufacturer. For more details, please contact your Manitou agent. This is not a contractually binding document. The presentation of the products is not contractually binding. List of specifications non-exhaustive. The logos as well as the visual identity of the company are owned by Manitou and cannot be used without authorisation. All rights reserved. The photos and diagrams contained in this brochure are only provided for consultation and information purposes.

MANITOU BF SA - Limited company with board of directors - Share capital: 39,668,399 euros - 857 802 508 RCS Nantes