

Fiche technique :

MC 18-4 ST5



Technical characteristics			Métrique
1.1	Manufacturer		Manitou
1.2	Model Name		MC 18-4 ST5
1.3	Power source		Diesel
1.4	Operator type		Seated
1.5	Max. capacity	Q	1800 kg
1.6	Load center of gravity	c	500 mm
1.8	Load distance, centre of drive axle to fork	x	616 mm
1.9	Wheelbase	y	1900 mm
Weight			
	Standard mast reference of the machine		FVD 33
2.1	Service weight		3590 kg
2.2	Weight on front axle (laden) / rear axle (laden)		4670 kg / 720 kg
2.3	Weight on front axle (Unladen) / rear axle (Unladen)		1660 kg / 1930 kg
Wheels			
3.1	Tires type		Pneumatic
3.2	Dimensions of front wheels		12,5/80-18/12 SL R4
3.3	Dimensions of rear wheels		27x10-12 SKS
3.5	Number of front wheels / rear wheels		2 / 2
3.5.2	Number of drive wheels		4
3.6	Front wheel gauge	b10	1159 mm
3.7	Rear wheel gauge	b11	1176 mm
Dimensions			
4.7	Height of overhead guard (cabin) / Overall height of low overhead guard (Buggie version)	h6 / h6*	2155 mm / 1990 mm
4.8	Seat height/stand height	h7	1094 mm
4.19	Overall length	l1	4100 mm
4.20	Length to face of forks	l2	2950 mm
4.21	Overall width	b1	1450 mm
4.22	Forks section x width x length	s / e / l	35 mm x 100 mm / 1150 mm
4.23	Fork carriage ISO 2328 (class/form) A/B		2A
4.24	Fork carriage width	b3	1260 mm
4.31	Ground clearance below mast	m1	300 mm
4.32	Ground clearance at centre of wheelbase	m2	310 mm
4.35	Turning radius	Wa	3370 mm
Performances			
5.1	Travel speed (laden / unladen)		12 km/h / 23.50 km/h
5.2	Lifting speed (laden / unladen)		0.44 m/s / 0.44 m/s
5.3	Lowering speed (laden / unladen)		0.40 m/s / 0.40 m/s
5.5	Drawbar pull (Laden)		1800 daN
5.7	Gradeability (laden)		35 %
5.10	Service brake		Hydraulic brakes by loss of pressure
Engine			
7.2	I.C. Engine power rating		27 kW
7.1	Engine brand / model / norm		Kubota / D1803 CR E5B / Stage V
7.3	Rated speed		2700 rpm
7.4	Number of cylinders / Capacity of cylinders		3 - 1826 cm³
Miscellaneous			
8.1	Type of drive control		Electronic
8.2	Working hydraulic pressure for attachments		160 bar
8.3	Oil flow rate for attachments		31 l/min

MC 18-4 ST5 - Schémas d'encombrement

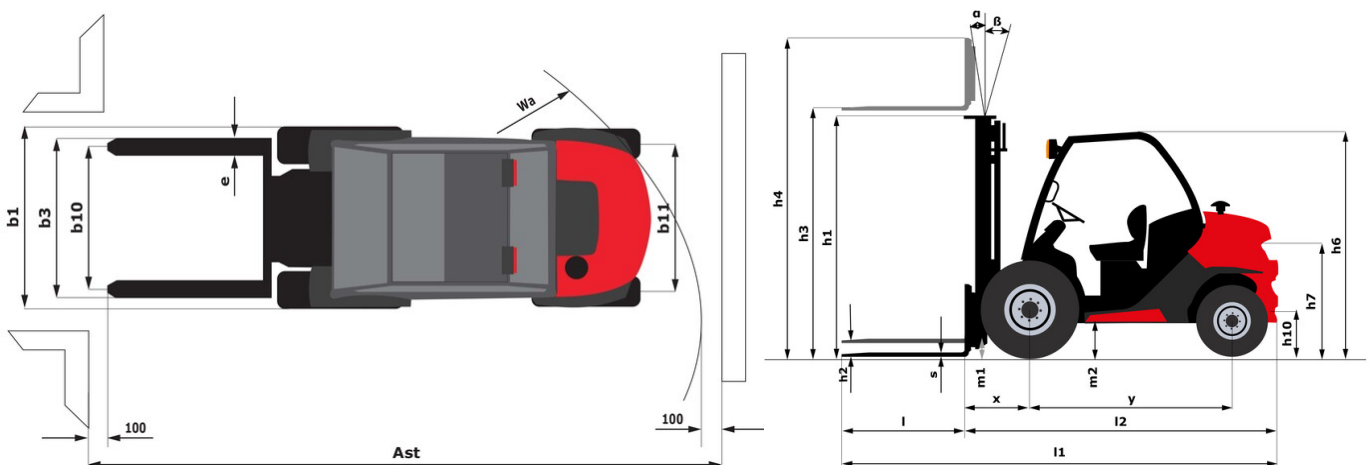

Caractéristiques des mâts et capacités résiduelles

Full Visibility Duplex (FVD)	FVD 33	FVD 37	FVD 40	FVD 45
α - Mast/fork carriage tilt, forward	°	12	12	12
β - Mast/fork carriage tilt, backward	°	10	10	10
h1 - Mast lowered height	mm	2348	2608	2798
h2 - Mast free lift	mm	85	85	85
h3 - Mast lifting height	mm	3300	3700	4000
h4 - Mast extended height	mm	4018	4428	4768
Residual capacity at max height	kg	1800	1800	1100
Residual capacity with hooked-on side shift at max height	kg	1800	1800	1100
Height at max capacity	mm	3300	3700	2500
Height at max capacity with hooked-on sideshift	mm	3300	3700	3600

Free Lift Triplex (FLT)	FLT 37	FLT 43	FLT 47	FLT 55
α - Mast/fork carriage tilt, forward	°	12	12	6
β - Mast/fork carriage tilt, backward	°	10	10	6
h1 - Mast lowered height	mm	1998	2198	2348
h2 - Mast free lift	mm	1305	1505	1655
h3 - Mast lifting height	mm	3700	4300	4700
h4 - Mast extended height	mm	4453	5053	5453
Residual capacity at max height	kg	1600	1000	600
Residual capacity with hooked-on side shift at max height	kg	1550	1000	600
Height at max capacity	mm	3400	3400	3400
Height at max capacity with hooked-on sideshift	mm	3300	3400	3400

Full Visibility Triplex (FVT)	FVT 33	
α - Mast/fork carriage tilt, forward	°	12
β - Mast/fork carriage tilt, backward	°	10
h1 - Mast lowered height	mm	1888
h2 - Mast free lift	mm	135
h3 - Mast lifting height	mm	3300
h4 - Mast extended height	mm	4048
Residual capacity at max height	kg	1800
Residual capacity with hooked-on side shift at max height	kg	1800
Height at max capacity	mm	3300
Height at max capacity with hooked-on sideshift	mm	3300



Siège Social

B.P. 249 - 430 rue de l'Aubinière

44150 Ancenis Cedex - France

Tel: +33 (0)2 40 09 10 11 - Fax: +33 (0)2 40 09 10 97

www.manitou.com



Cette publication présente le descriptif des versions et possibilités de configuration des produits Manitou qui peuvent différer en équipement. Les équipements présentés dans cette brochure peuvent être de série, en option, ou non disponibles suivant les versions. Manitou se réserve le droit, à tout moment et sans préavis, de modifier les spécifications décrites et représentées. Les spécifications portées n'engagent pas le constructeur. Pour plus de détails, contactez votre concessionnaire Manitou. Document non contractuel. Présentation des produits non contractuelle. Liste des spécifications non exhaustive. Les logos ainsi que l'identité visuelle de l'entreprise sont la propriété de Manitou et ne peuvent être utilisés sans autorisation. Tous droits réservés. Les photos et schémas contenus dans la présente brochure ne sont fournis qu'à des fins de consultation et à titre indicatif.

Manitou BF SA - Société anonyme à conseil d'administration - Capital social : 39 668 399 euros - 857 802 508 RCS Nantes