

Ficha técnica :

3300V NXT2



 **MANITOU**
HANDLING YOUR WORLD

Capacities		Métrico
Rated Operating Capacity		1497 kg
Unladen weight		4123 kg
Weight and dimensions		
Wheelbase	y	1257 mm
Overall Operating Height - Fully Raised	h27	4369 mm
Height to Hinge Pin - Fully Raised	h28	3332 mm
Overall Height to top of ROPS	h17	2083 mm
Dump angle at full height	a5	42 °
Dump height	h29	2502 mm
Overall length with bucket	l16	3874 mm
Dump reach - Full height	r6	813 mm
Rollback at ground	a13	29 °
Seat to ground height	h30	1041 mm
Overall width less bucket	b1	1829 mm
Bucket Width	e1	1880 mm
Ground clearance	m4	229 mm
Overall length - Less Bucket	l2	3023 mm
Departure angle	a2	25 °
Clearance Radius - Front with Bucket	b18	2400 mm
Performances		
Travel speed (unladen)		13 km/h
Travel Speed with Two-Speed Option - Maximum		19.60 km/h
Wheels		
Standard tires		14.00 x 17.5 HD
Engine		
Engine brand		Yanmar
Engine model		4TNV98CT-NMS
Engine norm		Stage V
Gross Power		53.70 kW
Net Power		52.70 kW
Max. torque / Engine rotation		294 Nm / 2500 rpm
Power source		Diesel
I.C. Engine power rating		72 Hp
Battery voltage		12 V
Alternator		95 kW
Starter		3 kW
Hydraulics		
Standard flow - Auxiliary hydraulics		89.10 l/min
Auxiliary Hydraulic Pressure		237.90 bar
High-Flow Auxiliary Hydraulics - Option		132 l/min
High-Flow Auxiliary Hydraulics Pressure - Option		220.60 bar
Tank capacities		
Fuel tank		92.70 l
Hydraulic tank capacity		40 l
Displacement		3.30 l
Noise and vibration		
Noise to environment (LwA)		101 dB
Noise at driving position (LpA)		85 dB
Whole-Body Vibration (ISO 2631-1)		0.79 m/s ²
Vibration on hands/arms		< 1.20 m/s ²

3300V NXT2 - Diagrama dimensional

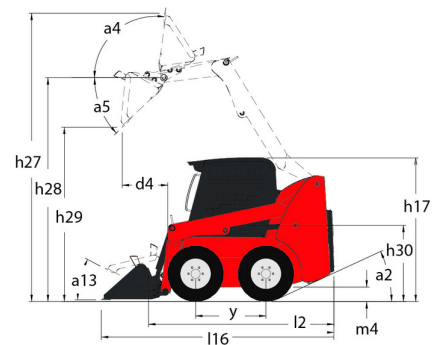
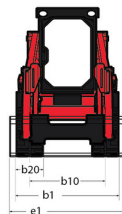
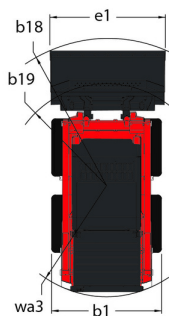

Equipamiento

—	
Integral Access Plate (removable)	Estándar
Lifting function	
All-Tach® Attachment Mounting System	Estándar
Auxiliary Hydraulics	Estándar
High-Flow Auxiliary Hydraulics	Opcional
Power-A-Tach® Attachment Mounting System	Opcional
Lighting	
Work Lights - Front and Rear	Estándar
Motorization/Power	
Engine Auto-Shutdown System	Estándar
Engine Block Heater	Opcional
Turbo-Charged Engine	Estándar
Two-Speed Drive	Estándar
Operator station	
Adjustable Arm Rests / Control Towers 1	Estándar
Air conditioning with manual adjustment	Opcional
Air suspension seat	Opcional
Cab Enclosure	Opcional
Dual-Hand Controls	Opcional
Foot and Hand Throttles 2	Estándar
Gehl T-Bar Controls	Opcional
Hand/Foot Controls	Opcional
Heating	Opcional
High-Back Adjustable Seat	Estándar
Horn	Estándar
Joystick controls	Opcional
ROPS/FOPS Level II Overhead Guard	Estándar
Sound Reduction Material	Estándar
Suspension Seat - Mechanical	Opcional
Other options	
Hydrostatic Drive - Servo	Estándar
Selectable Self-Leveling Hydraulic Lift Action 4	Opcional
Secondary functions	
Counterweight	Estándar
Full Instrumentation	Estándar
Hydraglide™ Ride Control 3	Estándar
Security	
Anti-Vandalism Protection	Estándar
Back-Up Alarm	Opcional
Brake Control (Auto / Manual)	Estándar
Hydraloc™ Safety System	Estándar
Lift Arm Support Device	Estándar
Operator Restraint Bar	Estándar



Oficina Central

B.P. 249 - 430 rue de l'Aubinière

44150 Ancenis Cedex - Francia

Tel.: 00 33 (0)2 40 09 10 11 - Fax: 00 33 (0)2 40 09 10 97

www.manitou.com



Esta publicación describe las versiones y posibilidades de configuración de los productos Manitou que puedan diferir en equipamiento. Los equipamientos presentados en este folleto pueden ser de serie, opcionales o no estar disponibles en algunas versiones. Manitou se reserva el derecho, en cualquier momento y sin previo aviso, de modificar las especificaciones descritas y representadas. Las especificaciones aportadas no comprometen al fabricante. Para más información, póngase en contacto con su concesionario Manitou. Documento no contractual. Presentación de los productos no contractual. Lista de especificaciones no exhaustiva. Los logos y la identidad visual de la empresa son propiedad de Manitou y no pueden ser utilizados sin autorización. Todos los derechos reservados. Las fotos y los esquemas contenidos en este folleto se ofrecen para consulta y a título indicativo solamente.

Manitou BF SA - Sociedad anónima con Consejo de Administración - Capital social: 39 668 399 euros - 857 802 508 RCS Nantes