

Scheda tecnica :

3300V NXT2



 **MANITOU**
HANDLING YOUR WORLD

Capacities		Metrico
Rated Operating Capacity		1497 kg
Unladen weight		4123 kg
Weight and dimensions		
Wheelbase	y	1257 mm
Overall Operating Height - Fully Raised	h27	4369 mm
Height to Hinge Pin - Fully Raised	h28	3332 mm
Overall Height to top of ROPS	h17	2083 mm
Dump angle at full height	a5	42 °
Dump height	h29	2502 mm
Overall length with bucket	l16	3874 mm
Dump reach - Full height	r6	813 mm
Rollback at ground	a13	29 °
Seat to ground height	h30	1041 mm
Overall width less bucket	b1	1829 mm
Bucket Width	e1	1880 mm
Ground clearance	m4	229 mm
Overall length - Less Bucket	l2	3023 mm
Departure angle	a2	25 °
Clearance Radius - Front with Bucket	b18	2400 mm
Performances		
Travel speed (unladen)		13 km/h
Travel Speed with Two-Speed Option - Maximum		19.60 km/h
Wheels		
Standard tires		14.00 x 17.5 HD
Engine		
Engine brand		Yanmar
Engine model		4TNV98CT-NMS
Engine norm		Stage V
Gross Power		53.70 kW
Net Power		52.70 kW
Max. torque / Engine rotation		294 Nm / 2500 rpm
Power source		Diesel
I.C. Engine power rating		72 Hp
Battery voltage		12 V
Alternator		95 kW
Starter		3 kW
Hydraulics		
Standard flow - Auxiliary hydraulics		89.10 l/min
Auxiliary Hydraulic Pressure		237.90 bar
High-Flow Auxiliary Hydraulics - Option		132 l/min
High-Flow Auxiliary Hydraulics Pressure - Option		220.60 bar
Tank capacities		
Fuel tank		92.70 l
Hydraulic tank capacity		40 l
Displacement		3.30 l
Noise and vibration		
Noise to environment (LwA)		101 dB
Noise at driving position (LpA)		85 dB
Whole-Body Vibration (ISO 2631-1)		0.79 m/s ²
Vibration on hands/arms		< 1.20 m/s ²

3300V NXT2 - Disegno quotato

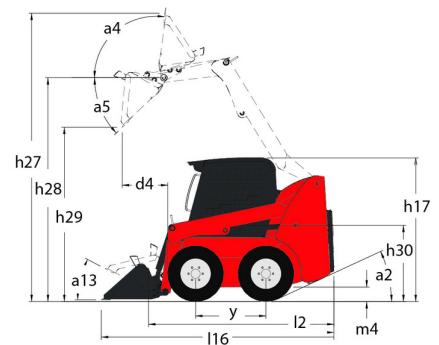

Allestimento

—	
Integral Access Plate (removable)	Standard
Lifting function	
All-Tach® Attachment Mounting System	Standard
Auxiliary Hydraulics	Standard
High-Flow Auxiliary Hydraulics	Optional
Power-A-Tach® Attachment Mounting System	Optional
Lighting	
Work Lights - Front and Rear	Standard
Motorization/Power	
Engine Auto-Shutdown System	Standard
Engine Block Heater	Optional
Turbo-Charged Engine	Standard
Two-Speed Drive	Standard
Operator station	
Adjustable Arm Rests / Control Towers 1	Standard
Air conditioning with manual adjustment	Optional
Air suspension seat	Optional
Cab Enclosure	Optional
Dual-Hand Controls	Optional
Foot and Hand Throttles 2	Standard
Gehl T-Bar Controls	Optional
Hand/Foot Controls	Optional
Heating	Optional
High-Back Adjustable Seat	Standard
Horn	Standard
Joystick controls	Optional
ROPS/FOPS Level II Overhead Guard	Standard
Sound Reduction Material	Standard
Suspension Seat - Mechanical	Optional
Other options	
Hydrostatic Drive - Servo	Standard
Selectable Self-Leveling Hydraulic Lift Action 4	Optional
Secondary functions	
Counterweight	Standard
Full Instrumentation	Standard
Hydraglide™ Ride Control 3	Standard
Security	
Anti-Vandalism Protection	Standard
Back-Up Alarm	Optional
Brake Control (Auto / Manual)	Standard
Hydraloc™ Safety System	Standard
Lift Arm Support Device	Standard
Operator Restraint Bar	Standard



Sede centrale

MANITOU ITALIA Srl

Via Cristoforo Colombo 2, Loc. Cavazzona - 41013 CASTELFRANCO EMILIA (MO)

Tel: 059.95.98.11 - Fax 059.95.98.65

www.manitou.com



Questa pubblicazione presenta la descrizione delle versioni e delle possibilità di configurazione dei prodotti Manitou, che possono differire per attrezzature. Gli allestimenti presentati nel presente opuscolo possono essere di serie, optional o non disponibili, a seconda delle versioni. Manitou si riserva il diritto di modificare, in qualsiasi momento e senza alcun preavviso, le specifiche tecniche descritte e rappresentate. Le specifiche indicate non rappresentano alcun obbligo per il costruttore. Per maggiori dettagli, rivolgersi al proprio concessionario Manitou. Documento non contrattuale. Elenco delle specifiche non esaustivo. I loghi nonché l'identità visiva dell'azienda sono di proprietà di Manitou e non possono essere utilizzati senza autorizzazione. Tutti i diritti riservati. Le immagini e gli schemi contenuti nel presente opuscolo sono forniti esclusivamente a fini di consultazione e a titolo indicativo.

Manitou BF SA - Società anonima con consiglio di amministrazione. Capitale sociale: 39,668,399 euro - 857 802 508 RCS Nantes