

Technical sheet :

280 TJ-X



 **MANITOU**
HANDLING YOUR WORLD

Capacities		Metric
Working height	h21	27.73 m
Platform height	h7	25.73 m
Max. outreach		21.45 m
Pendular arm rotation (top / bottom)		+56.80 ° / -62 °
Platform capacity / capacity (maximum)	Q	240 kg / 350 kg
Turret rotation		360 °
Platform rotation (right / left)		90 ° / 90 °
Number of people (indoor / outdoor)		2 / 3
Weight and dimensions		
Platform weight*		16650 kg
Platform dimensions (length x width)	lp / ep	2.30 m x 0.90 m
Floor height (access)	h20	0.48 m
Overall length	l1	11.36 m
Overall width	b1	2.48 m
Overall height	h17	2.73 m
Overall length (stowed)	l9	8.09 m
Overall height (stowed)	h18 ***	2.71 m
Overall length with platform extension	l15	11.35 m
Counterweight Oversize / Reach		1.45 m
Ground clearance at centre of wheelbase	m2	0.41 m
Wheelbase	y	2.80 m
Performances		
Drive speed - stowed		4.50 km/h
Drive speed - raised		0.80 km/h
Gradeability		34 %
Permissible leveling		4 °
Wheels		
Drive wheels (front / rear)		2 / 2
Braking wheels (front / rear)		2 / 2
Engine/Battery		
Engine brand / model		Kubota - V2403-M
I.C. Engine power rating / Power		46 Hp / 34.10 kW
Miscellaneous		
Ground Pressure		22.25 dan/cm2
Hydraulic Pressure		250 bar
Fuel tank		72 l
Vibration on hands/arms		< 0.50 m/s ²
Daily consumption **		10.81 l
Standards compliance		
This machine is in compliance with:		European directives: 2006/42/EC - Machinery (revised EN280:2013) - 2004/108/EC (EMC) - 2006/95/EC (Low voltage)

*Varies according to options and standards of the country to which the machine is delivered

** According to "REDUCE cycle"

280 TJ-X - Load chart

Load Chart for MEWP Metric

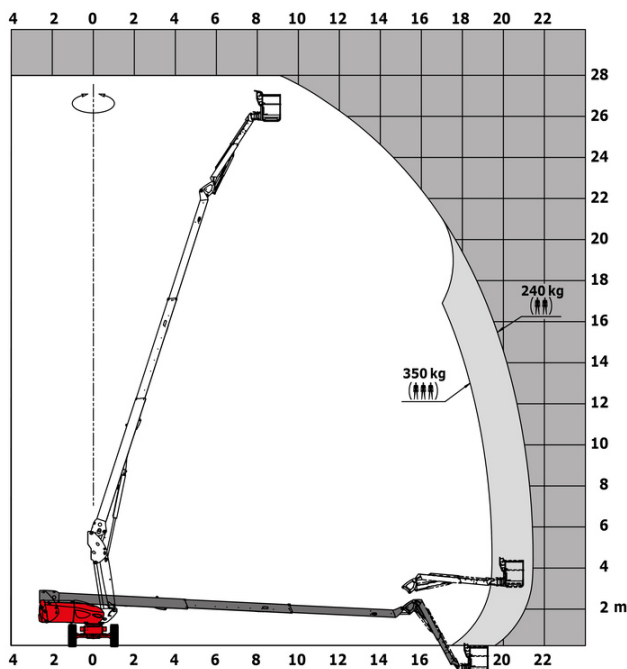

Equipment

Standard

20" tyres
230V Predisposition
4 simultaneous movements
4 wheel drive
4 wheel steer with crab mode
Audible alarm and illuminated indicator lamp (leveling, overload, lowering)
Backup electrical pump
CAN bus technology
Continuous turret rotation
Dead man pedal
Differential locking on rear axle
Electronic platform compensation
Emergency stop button in platform and on frame
Engine on swivel chair
Front axle with limited slip
Fuel gauge with low level indicator
Hom in the platform
Integrated diagnostic assistance
Oscillating front axle
Painted basket for heavy loads 2,300 mm (7ft 7 in.)

Optional

110 or 230V plug with differential circuit breaker
Additional storage boxes
Basket 1,800 mm
Biodegradable oil
Catalytic cleaner
Coded anti-start
Cold weather protection oil
High capacity starting battery
Key lock on turret cover
Lockable fuel cap
Non-marking tyres
On-board generator (3,5 or 5 kW)
Refinery kit
SMS : Safe Man System
Safety harness
Screen protection on the lower box control
Water predisposition



Head Office

B.P. 249 - 430 rue de l'Aubinière

44150 Ancenis Cedex - France

Tel: +33 (0)2 40 09 10 11 - Fax: +33 (0)2 40 09 10 97

www.manitou.com



This publication provides a description of the configuration versions and options for Manitou products, which may differ for equipment. The equipment presented in this brochure may be part of a series, as an option, or it may not be available, depending on the versions. Manitou reserves the right, at any time and without notice, to amend the specifications described and represented. The specifications provided do not bind the manufacturer. For more details, please contact your Manitou agent. This is not a contractually binding document. The presentation of the products is not contractually binding. List of specifications non-exhaustive. The logos as well as the visual identity of the company are owned by Manitou and cannot be used without authorisation. All rights reserved. The photos and diagrams contained in this brochure are only provided for consultation and information purposes.

MANITOU BF SA - Limited company with board of directors - Share capital: 39,668,399 euros - 857 802 508 RCS Nantes