

Technical sheet :

# 200 ATJ-X



Capacities		Metric
Working height	h21	20.28 m
Platform height	h7	18.28 m
Max. outreach		12 m
Overhang		8 m
Pendular arm rotation (top / bottom)		+69 ° / -66 °
Platform capacity	Q	230 kg
Turret rotation		355 °
Platform rotation (right / left)		90 ° / 90 °
Number of people (indoor / outdoor)		2 / 2
Weight and dimensions		
Platform weight*		10050 kg
Platform dimensions (length x width)	lp / ep	2.10 m x 0.80 m
Floor height (access)	h20	0.51 m
Overall length	l1	8.42 m
Overall width	b1	2.40 m
Overall height	h17	2.71 m
Overall length (stowed)	l9	6.21 m
Overall height (stowed)	h18 ***	2.85 m
Counterweight offset (turret at 90°)	a7	0.11 m
Counterweight Oversize / Reach		0.11 m
External turning radius	Wa3	4.17 m
Ground clearance at centre of wheelbase	m2	0.44 m
Wheelbase	y	2.40 m
Performances		
Drive speed - stowed		4.70 km/h
Drive speed - raised		0.80 km/h
Gradeability		40 %
Permissible leveling		5 °
Wheels		
Tires type		Solid Tires Cured-On
Standard tires		1025 x 365 mm
Drive wheels (front / rear)		2 / 2
Steering wheels (front / rear)		2 / 2
Braking wheels (front / rear)		0 / 2
Engine/Battery		
Engine brand / model		Kubota - V2403-M
Engine norm		Stage IIIA
I.C. Engine power rating / Power		46 Hp / 34.10 kW
Miscellaneous		
Ground Pressure		20.65 dan/cm2
Hydraulic Pressure		335 bar
Hydraulic tank capacity		80 l
Fuel tank		78 l
Vibration on hands/arms		< 0.50 m/s <sup>2</sup>
Daily consumption **		7.96 l
Standards compliance		
This machine is in compliance with:		European directives: 2006/42/EC- Machinery (revised EN280:2013) - 2004/108/EC (EMC) - 2006/95/EC (Low voltage)

\*Varies according to options and standards of the country to which the machine is delivered

\*\* According to "REDUCE cycle"

# 200 ATJ-X - Load chart

Load Chart metric



# 200 ATJ-X - Dimensional drawing

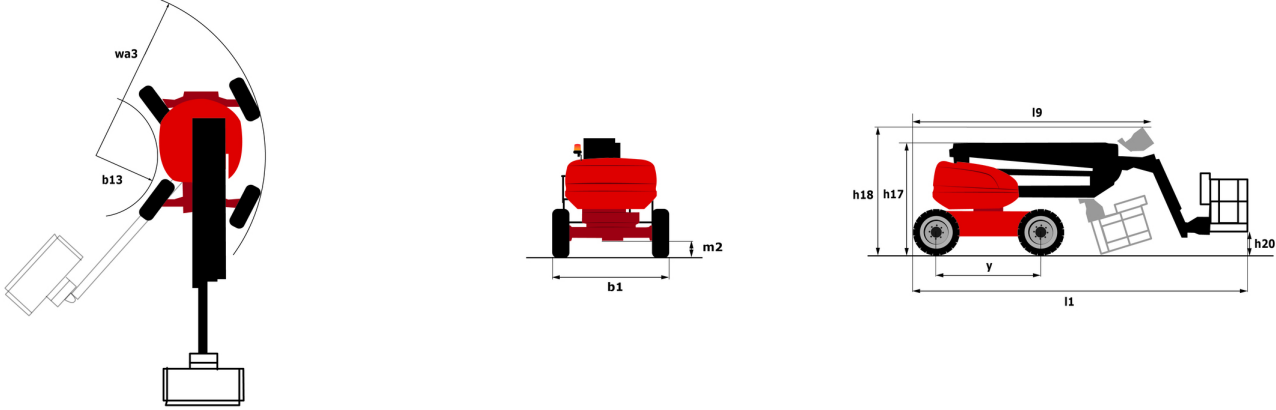

# Equipment

---

## Standard

230V Predisposition  
4 simultaneous movements  
4 wheel drive  
4 wheel steer with crab mode  
Audible alarm and illuminated indicator lamp (leveling, overload, lowering)  
Backup electrical pump  
CAN bus technology  
Dead man pedal  
Differential locking on rear axle  
Fuel gauge with low level indicator  
Galvanized basket 2,100 mm  
Hour meter  
Management via engine speed bearing  
Oscillating front axle  
Proportional controls

## Optional

110 or 230V plug with differential circuit breaker  
Battery cut-off  
Biodegradable oil  
Catalytic cleaner  
Coded anti-start  
Cold weather protection oil  
Continuous turret rotation  
High capacity starting battery  
Key lock on fuel tank  
Key lock on turret cover  
On-board generator (3,5 or 5 kW)  
SMS : Safe Man System  
Safety harness  
Screen protection on the lower box control  
Spark arrester  
Water heater  
Working light



**Head Office**

B.P. 249 - 430 rue de l'Aubinière

44150 Ancenis Cedex - France

Tel: +33 (0)2 40 09 10 11 - Fax: +33 (0)2 40 09 10 97

[www.manitou.com](http://www.manitou.com)



This publication provides a description of the configuration versions and options for Manitou products, which may differ for equipment. The equipment presented in this brochure may be part of a series, as an option, or it may not be available, depending on the versions. Manitou reserves the right, at any time and without notice, to amend the specifications described and represented. The specifications provided do not bind the manufacturer. For more details, please contact your Manitou agent. This is not a contractually binding document. The presentation of the products is not contractually binding. List of specifications non-exhaustive. The logos as well as the visual identity of the company are owned by Manitou and cannot be used without authorisation. All rights reserved. The photos and diagrams contained in this brochure are only provided for consultation and information purposes.

MANITOU BF SA - Limited company with board of directors - Share capital: 39,668,399 euros - 857 802 508 RCS Nantes