

Ficha técnica :

2150RT



 **MANITOU**
HANDLING YOUR WORLD

Capacities		Métrico
Max. capacity	Q	2787 kg
Operating Weight		4491 kg
Unladen weight		4491 kg
Operating Capacity at 35% Tipping Load		975 kg
Operating Capacity At 50% Tipping Load		1393 kg
Tipping capacity		2787 kg
Weight and dimensions		
Overall Operating Height - Fully Raised	h27	4267 mm
Height to Hinge Pin - Fully Raised	h28	3251 mm
Dump reach - Full height	r6	876 mm
Dump angle at full height	a5	39 °
Dump Height - Fully Raised	h29	2489 mm
Maximum Rollback Angle - Fully Raised	a4	102.50 °
Overall Height to top of ROPS	h17	2111 mm
Overall length with bucket	l16	3769 mm
Departure angle	a2	29.20 °
Overall Length without Bucket	l1	2959 mm
Specified Height	h31	1720 mm
Reach at Specified Height	r4	795 mm
Dump angle at specified height	a17	75 °
Carry Position	d5	208 mm
Maximum Rollback Angle at Carry Position	a14	31.60 °
Digging Position	h32	16 mm
Angle of Departure with STD Counterweight		29.20 °
Ground clearance	m4	320 mm
Track gauge	b10	1313 mm
Track Shoe Width	b20	450 mm
Crawler base	y2	1483 mm
Overall width less bucket	b1	1765 mm
Bucket Width	e1	1877 mm
Clearance Radius - Front with Bucket	b18	2403 mm
Angle of Approach	a3	90 °
Grouser Height		25 mm
Track Type / Track Rollers / Roller Type		Rubber / 5 / Steel
Performances		
Ground Speed - Single Speed		9.50 km/h
Ground Speed - Two Speed		14.20 km/h
Drawbar Pull/Tractive Effort		5503 kg
Bucket Breakout - Tilt Cylinder		3008 kg
Bucket Breakout - Lift Cylinder		2940 kg
Engine		
Engine brand		Yanmar
Engine model		TNV98CFNMSL
Motor Type		Axial Piston with Planetary Gear Box Reduction
Gross Power / Power		53.70 kW @ 2500 rpm
Net Power / Power		52.70 kW / 2500 rpm
Max. torque		294 Nm
I.C. Engine power rating		72 Hp
Battery voltage		12 V
Cold Cranking Amps at Temperature (CCA)		850 A
Alternator - Voltage / Ampere		14 V / 100 A
Hydraulics		
Standard flow - Auxiliary hydraulics		82.51 l/min
Tank capacities		
Oil Pan Capacity		10.40 l
Hydraulic tank capacity		52.20 l
Fuel tank		91 l
Liquid cooling tank volume		14.40 l
Displacement / Number of cylinders		3.30 l / 4
Noise and vibration		
Noise to environment (LwA)		103 dB
Noise at driving position (LpA)		83 dB
Miscellaneous		
Ground Pressure		0.33 bar

2150RT - Diagrama dimensional

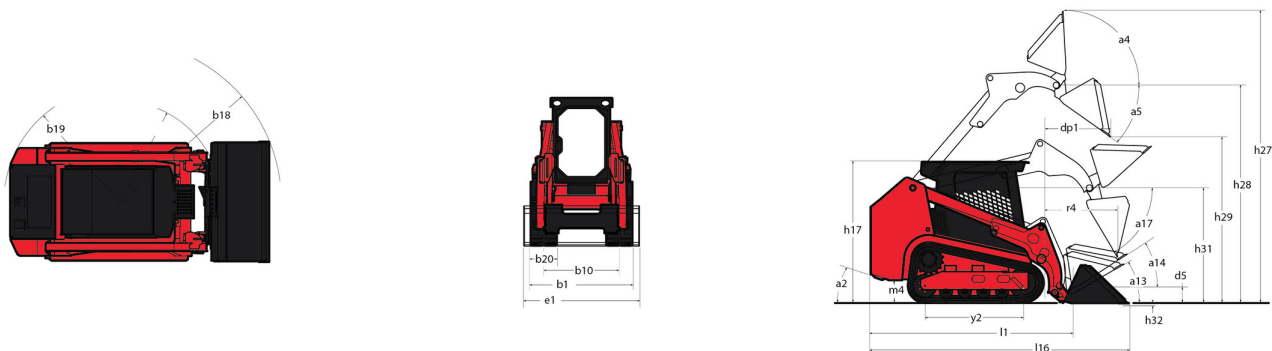

Equipamiento

Lifting function	
All-Tach® Attachment Mounting System	Estándar
Auxiliary Hydraulics	Estándar
Electronic Attachment Control - 14-Pin Connector	Opcional
High-Flow Auxiliary Hydraulics	Opcional
IdealTrax® automatic track tensioning system	Estándar
Power-A-Tach® Attachment Mounting System	Opcional
Motorization/Power	
Combination Radiator & Hydraulic Oil Cooler	Estándar
Dual-Element Air Cleaner with Indicator	Estándar
Engine Auto-Shutdown System	Estándar
Glowplugs Starts Assist	Estándar
Two-Speed Hydrostatic Drive System	Estándar
Operator station	
Air suspension seat	Opcional
Foot Throttle	Estándar
Full-Suspension Seat	Estándar
IdealAccess™ Fold-Up Door	Opcional
Multi-Function Display Screen	Estándar
Pressurized Cab Enclosure with A/C	Opcional
Rearview Camera	Estándar
ROPS/FOPS Level II Overhead Guard	Estándar
Sliding Side Windows	Estándar
Swing-out Cab Door	Estándar
Other options	
Selectable Self-Leveling Hydraulic Lift Action 4	Opcional
Pneumatics	
Rubber Track Undercarriage System	Estándar
Single Flange Front/Dual Flange Rear Idlers	Estándar
Secondary functions	
Counterweight	Estándar
Dedicated Undercarriage	Estándar
Security	
Anti-Vandalism Lock Provisions	Estándar
Back-Up Alarm	Estándar
Easy Manager	Estándar
Engine Alert System with Error Display	Estándar
Mechanical Lift Cylinder Lock	Estándar
Tilt-out Foot Pod	Estándar



Oficina Central

B.P. 249 - 430 rue de l'Aubinière

44150 Ancenis Cedex - Francia

Tel.: 00 33 (0)2 40 09 10 11 - Fax: 00 33 (0)2 40 09 10 97

www.manitou.com



Esta publicación describe las versiones y posibilidades de configuración de los productos Manitou que puedan diferir en equipamiento. Los equipamientos presentados en este folleto pueden ser de serie, opcionales o no estar disponibles en algunas versiones. Manitou se reserva el derecho, en cualquier momento y sin previo aviso, de modificar las especificaciones descritas y representadas. Las especificaciones aportadas no comprometen al fabricante. Para más información, póngase en contacto con su concesionario Manitou. Documento no contractual. Presentación de los productos no contractual. Lista de especificaciones no exhaustiva. Los logos y la identidad visual de la empresa son propiedad de Manitou y no pueden ser utilizados sin autorización. Todos los derechos reservados. Las fotos y los esquemas contenidos en este folleto se ofrecen para consulta y a título indicativo solamente.

Manitou BF SA - Sociedad anónima con Consejo de Administración - Capital social: 39 668 399 euros - 857 802 508 RCS Nantes