

Fiche technique :

# 2150RT

---



 **MANITOU**  
HANDLING YOUR WORLD

Capacities		Métrique
Max. capacity	Q	2787 kg
Operating Weight		4491 kg
Unladen weight		4491 kg
Operating Capacity at 35% Tipping Load		975 kg
Operating Capacity At 50% Tipping Load		1393 kg
Tipping capacity		2787 kg
Weight and dimensions		
Overall Operating Height - Fully Raised	h27	4267 mm
Height to Hinge Pin - Fully Raised	h28	3251 mm
Dump reach - Full height	r6	876 mm
Dump angle at full height	a5	39 °
Dump Height - Fully Raised	h29	2489 mm
Maximum Rollback Angle - Fully Raised	a4	102.50 °
Overall Height to top of ROPS	h17	2111 mm
Overall length with bucket	l16	3769 mm
Departure angle	a2	29.20 °
Overall Length without Bucket	l1	2959 mm
Specified Height	h31	1720 mm
Reach at Specified Height	r4	795 mm
Dump angle at specified height	a17	75 °
Maximum Rollback Angle at Ground	a13	30 °
Carry Position	d5	208 mm
Maximum Rollback Angle at Carry Position	a14	31.60 °
Digging Position	h32	16 mm
Angle of Departure with STD Counterweight		29.20 °
Ground clearance	m4	320 mm
Track gauge	b10	1313 mm
Track Shoe Width	b20	450 mm
Crawler base	y2	1483 mm
Overall width less bucket	b1	1765 mm
Bucket Width	e1	1877 mm
Clearance Radius - Front with Bucket	b18	2403 mm
Clearance Circle - Rear	wa1	1641 mm
Maximum rollback at specified height		66.80 °
Angle of Approach	a3	90 °
Grouser Height		25 mm
Track Type / Track Rollers / Roller Type		Rubber / 5 / Steel
Performances		
Ground Speed - Single Speed		9.50 km/h
Ground Speed - Two Speed		14.20 km/h
Drawbar Pull/Ttractive Effort		5503 kg
Bucket Breakout - Tilt Cylinder		3008 kg
Bucket Breakout - Lift Cylinder		2940 kg
Engine		
Engine brand		Yanmar
Engine model		TNV98CT-NMSL
Motor Type		Axial Piston with Planetary Gear Box Reduction
Gross Power / Power		53.70 kW @ 2500 rpm
Net Power / Power		52.70 kW / 2500 rpm
Max. torque		294 Nm
I.C. Engine power rating		72 Hp
Battery voltage		12 V
Cold Cranking Amps at Temperature (CCA)		850 A
Alternator - Voltage / Ampere		14 V / 100 A
Hydraulics		
Standard flow - Auxiliary hydraulics		82.51 l/min
Tank capacities		
Oil Pan Capacity		10.40 l
Hydraulic tank capacity		52.20 l
Fuel tank		91 l
Liquid cooling tank volume		14.40 l
Displacement / Number of cylinders		3.30 l / 4
Noise and vibration		
Noise to environment (LWA)		103 dB
Noise at driving position (LpA)		83 dB
Miscellaneous		
Ground Pressure		0.33 bar

## 2150RT - Schémas d'encombrement

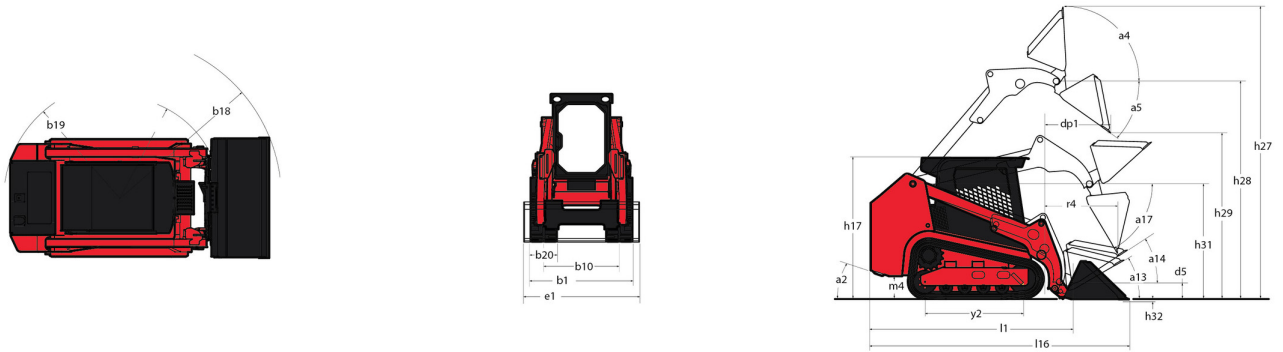

## Équipements

<b>Lifting function</b>	
All-Tach® Attachment Mounting System	Série
Auxiliary Hydraulics	Série
Electronic Attachment Control - 14-Pin Connector	Option
High-Flow Auxiliary Hydraulics	Option
IdealTrax® automatic track tensioning system	Série
Power-A-Tach® Attachment Mounting System	Option
<b>Motorization/Power</b>	
Combination Radiator & Hydraulic Oil Cooler	Série
Dual-Element Air Cleaner with Indicator	Série
Engine Auto-Shutdown System	Série
Glowplugs Starts Assist	Série
Two-Speed Hydrostatic Drive System	Série
<b>Operator station</b>	
Air suspension seat	Option
Foot Throttle	Série
Full-Suspension Seat	Série
IdealAccess™ Fold-Up Door	Option
Multi-Function Display Screen	Série
Pressurized Cab Enclosure with A/C	Option
Rearview Camera	Série
ROPS/FOPS Level II Overhead Guard	Série
Sliding Side Windows	Série
Swing-out Cab Door	Série
<b>Other options</b>	
Selectable Self-Leveling Hydraulic Lift Action 4	Option
<b>Pneumatics</b>	
Rubber Track Undercarriage System	Série
Single Flange Front/Dual Flange Rear Idlers	Série
<b>Secondary functions</b>	
Counterweight	Série
Dedicated Undercarriage	Série
<b>Security</b>	
Anti-Vandalism Lock Provisions	Série
Back-Up Alarm	Série
Easy Manager	Série
Engine Alert System with Error Display	Série
Mechanical Lift Cylinder Lock	Série
Tilt-out Foot Pod	Série



 **MANITOU**  
**HANDLING YOUR WORLD**

**Siège Social**

B.P. 249 - 430 rue de l'Aubinière

44150 Ancenis Cedex - France

Tel: +33 (0)2 40 09 10 11 - Fax: +33 (0)2 40 09 10 97

[www.manitou.com](http://www.manitou.com)



Cette publication présente le descriptif des versions et possibilités de configuration des produits Manitou qui peuvent différer en équipement. Les équipements présentés dans cette brochure peuvent être de série, en option, ou non disponibles suivant les versions. Manitou se réserve le droit, à tout moment et sans préavis, de modifier les spécifications décrites et représentées. Les spécifications portées n'engagent pas le constructeur. Pour plus de détails, contactez votre concessionnaire Manitou. Document non contractuel. Présentation des produits non contractuelle. Liste des spécifications non exhaustive. Les logos ainsi que l'identité visuelle de l'entreprise sont la propriété de Manitou et ne peuvent être utilisés sans autorisation. Tous droits réservés. Les photos et schémas contenus dans la présente brochure ne sont fournis qu'à des fins de consultation et à titre indicatif.

Manitou BF SA - Société anonyme à conseil d'administration - Capital social : 39 668 399 euros - 857 802 508 RCS Nantes