

Scheda tecnica :

# MLT 420-60 H



 **MANITOU**  
HANDLING YOUR WORLD

Capacities		Metrico
Max. capacity	Q	2000 kg
Max. lifting height	h3	4.35 m
Max. outreach		2.65 m
Reach at max. height		1 m
Breakout force with bucket		1886 daN
Weight and dimensions		
Unladen weight (with forks)		4190 kg
Ground clearance	m4	0.26 m
Wheelbase	y	2.13 m
Overall length to carriage (with hitch)	l11	3.64 m
Overall length to carriage (without hitch)	l3	3.64 m
Front overhang		1.04 m
Overall width	b1	1.49 m
Overall cab width	b4	0.80 m
Overall height	h17	1.96 m
Tilt-down angle	a5	116 °
Tilt-up angle	a4	12 °
External turning radius (over tyres)	Wa1	3.06 m
Standard tires		CAMSO - SKS532 - 12-16.5 145A2
Drive wheels (front / rear)		2 / 2
Steering wheels (front / rear)		2 / 2
Performances		
Lifting		5 s
Lowering		3.50 s
Extension		4.80 s
Retraction		3 s
Crowd		3.30 s
Dump		2.70 s
Engine		
Engine brand		Kubota
Engine nom		Stage V
Engine model		V2607-CR-E5B
Number of cylinders - Capacity of cylinders		4 - 2615 cm³
I.C. Engine power rating / Power		57 Hp / 42 kW
Max. torque / Engine rotation		174 Nm @1600 rpm
Drawbar pull (Laden)		2850 daN
Reversible fan		Standard
Engine cooling system		2 radiators water + hydraulic oil
Transmission		
Transmission type		Hydrostatic
Number of gears (forward / reverse)		2 / 2
Max. travel speed (may vary according to applicable regulations)		25 km/h
Differential lock		Limited slip differential on front axle
Parking brake		Automatic negative parking brake
Hydraulics		
Hydraulic pump type		Gear pump
Hydraulic flow - Pressure		77 l/min - 235 bar
Tank capacities		
Hydraulic tank capacity		70 l
Fuel tank		60 l
Noise and vibration		
Noise at driving position (LpA) tested following NF EN 12053 nom		76 dB
Noise to environment (LWA)		104 dB
Vibration on hands/arms		< 2.50 m/s²
Miscellaneous		
Tractor homologation		
Safety cab homologation		ROPS - FOPS cab (level 1)
Controls		JSM

## Optional tires tab

	Overall height	Overall width
ALLIANCE - A550 - 305/70 R16.5 141A5	1.96 m	1.48 m
TRELLEBORG - TH400 - 11LR16 130A8	1.97 m	1.49 m

## MLT 420-60 H - Disegno quotato

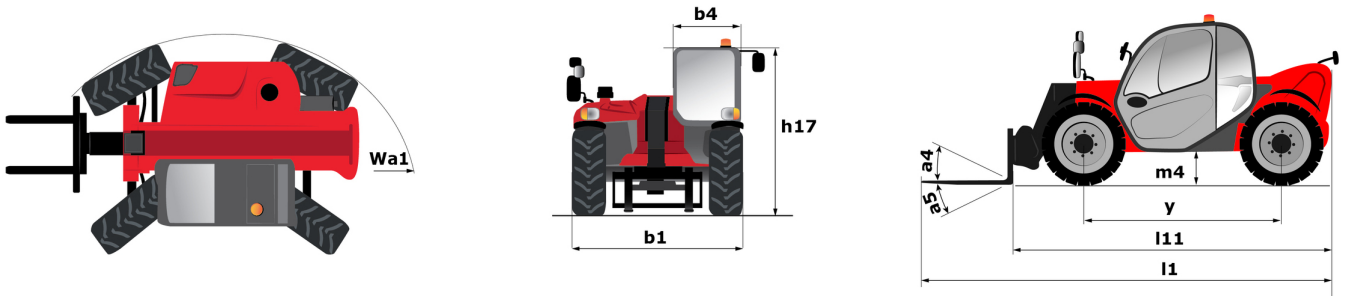

## MLT 420-60 H - Diagramma di carico

Machine on tires with forks Metric

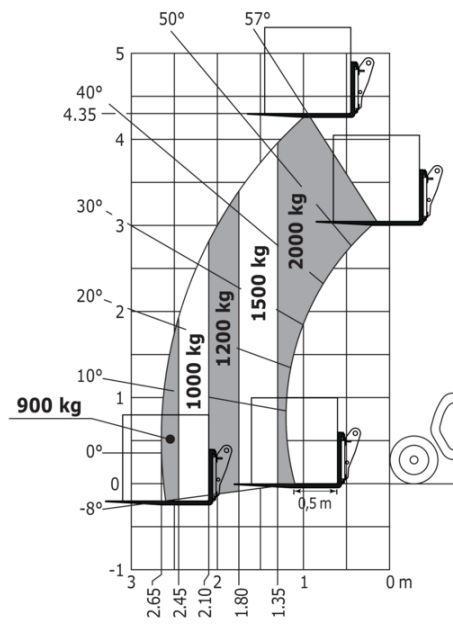



 **MANITOU**  
**HANDLING YOUR WORLD**

**Sede centrale**

MANITOU ITALIA Srl

Via Cristoforo Colombo 2, Loc. Cavazzona - 41013 CASTELFRANCO EMILIA (MO)

Tel: 059.95.98.11 - Fax 059.95.98.65

[www.manitou.com](http://www.manitou.com)



Questa pubblicazione presenta la descrizione delle versioni e delle possibilità di configurazione dei prodotti Manitou, che possono differire per attrezzature. Gli allestimenti presentati nel presente opuscolo possono essere di serie, optional o non disponibili, a seconda delle versioni. Manitou si riserva il diritto di modificare, in qualsiasi momento e senza alcun preavviso, le specifiche tecniche descritte e rappresentate. Le specifiche indicate non rappresentano alcun obbligo per il costruttore. Per maggiori dettagli, rivolgersi al proprio concessionario Manitou. Documento non contrattuale. Elenco delle specifiche non esaustivo. I loghi nonché l'identità visiva dell'azienda sono di proprietà di Manitou e non possono essere utilizzati senza autorizzazione. Tutti i diritti riservati. Le immagini e gli schemi contenuti nel presente opuscolo sono forniti esclusivamente a fini di consultazione e a titolo indicativo.

Manitou BF SA - Società anonima con consiglio di amministrazione. Capitale sociale: 39,668,399 euro - 857 802 508 RCS Nantes