

Fiche technique :

# MHT-X 11250 MINING

---



Capacities		Métrique
Max. capacity		24999 kg
Load center of gravity	c	900 mm
Max. lifting height		10.60 m
Max. outreach		6 m
Weight and dimensions		
Overall length	l1	8.92 m
Unladen weight (with forks)		31610 kg
Ground clearance	m4	0.47 m
Wheelbase	y	4.10 m
Length to face of forks	l2	7.12 m
Overall width	b1	2.84 m
Overall height	h17	3.03 m
Overall cab width	b4	0.95 m
Tilt-up angle	a4	12 °
Tilt-down angle	a5	105 °
External turning radius (over tyres)	Wa1	5.50 m
Forks length / width / section	l / e / s	1800 mm x 220 mm x 100 mm
Frame leveling corrector	a9	10 °
Wheels		
Standard tires		18.00 R25
Number of front wheels / rear wheels		2 / 2
Drive wheels (front / rear)		2 / 2
Steering mode		2 wheel steer, 4 wheel steer, Crab mode
Engine		
Engine brand		Yanmar
Engine nom		Stage IIIA
Engine model		4TN107TF-6SMU2
Number of cylinders / Capacity of cylinders		4 - 4567 cm³
I.C. Engine power rating / Power		211 Hp / 155 kW
Max. torque / Engine rotation		805 Nm@1500 rpm
Engine cooling system		Water
Number of batteries		2
Battery voltage		12 V
Transmission		
Transmission type		Hydrostatic
Number of gears (forward / reverse)		2 / 2
Max. travel speed		25 km/h
Parking brake		Automatic negative parking brake
Service brake		Oil-immersed multi-discs braking on front & rear axles
Gradeability (laden / unladen)		57.70 % / 31.50 %
Hydraulics		
Hydraulic pump type		Variable displacement pump
Hydraulic flow - Pressure		275 l/min - 350 bar
Tank capacities		
Engine oil		13 l
Fuel tank		315 l
Miscellaneous		
Safety cab homologation		Cabin ROPS - FOPS level 2
Controls		JSM

## MHT-X 11250 Mining - Schémas d'encombrement

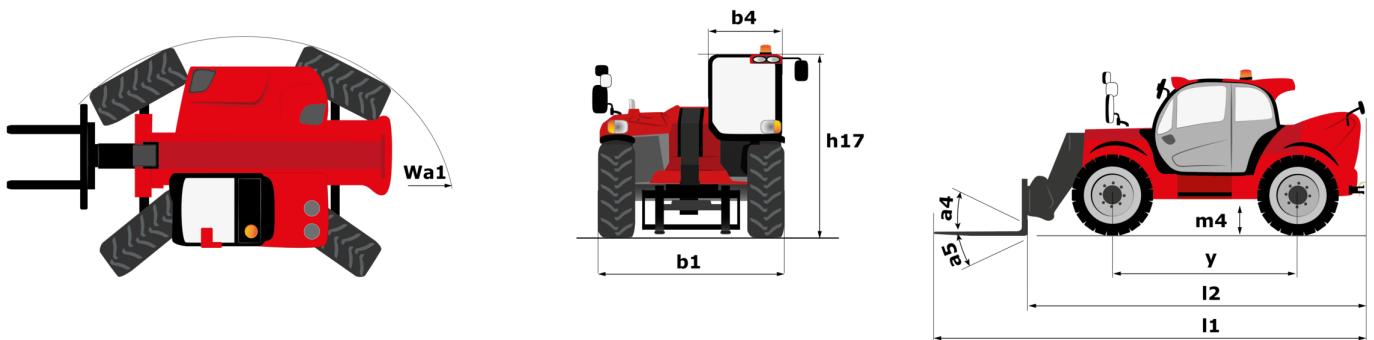

# MHT-X 11250 Mining - Abaques

## Machine on tires with forks LC 900 mm Metric

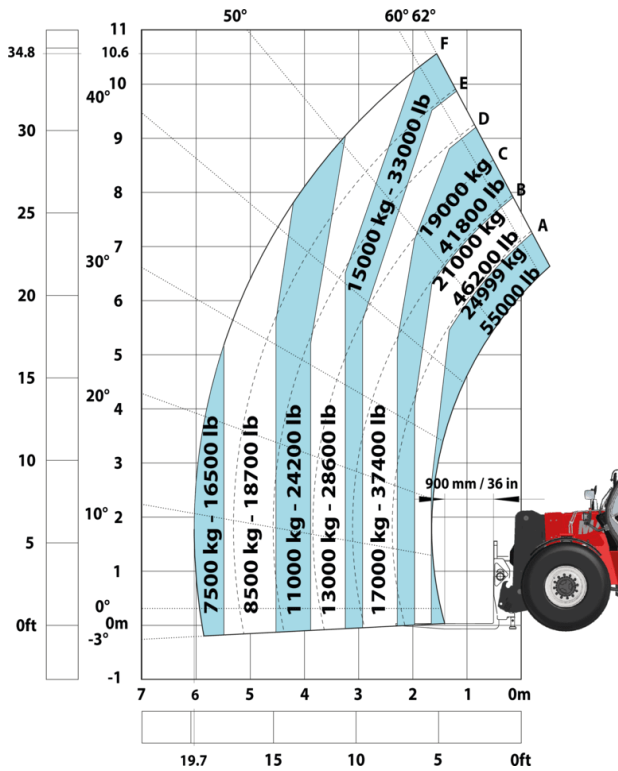

## Machine on tires with forks LC 1200 mm Metric

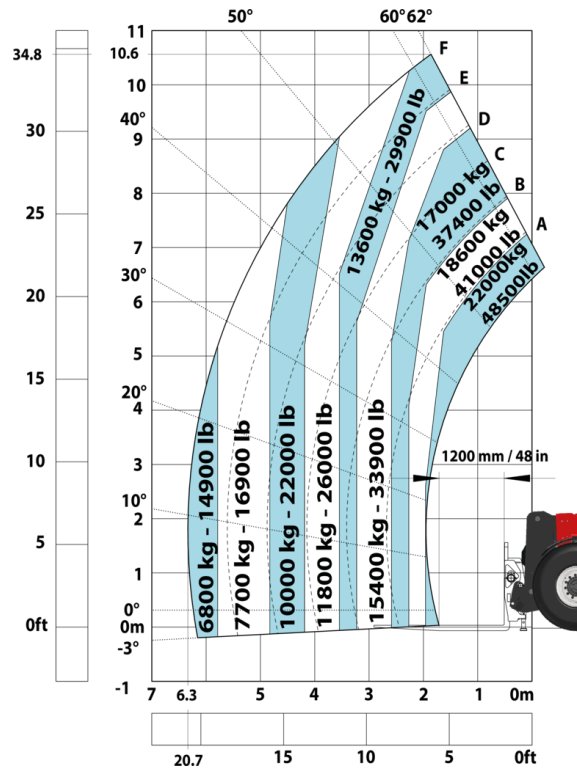

## Machine on tires with winch 25000 kg (Metric)

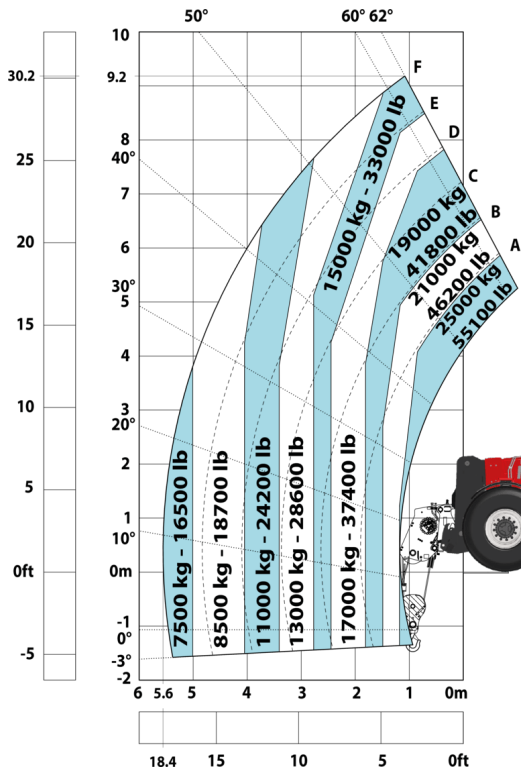

## Machine on tires with 3-hook jib 25000 kg (Metric)

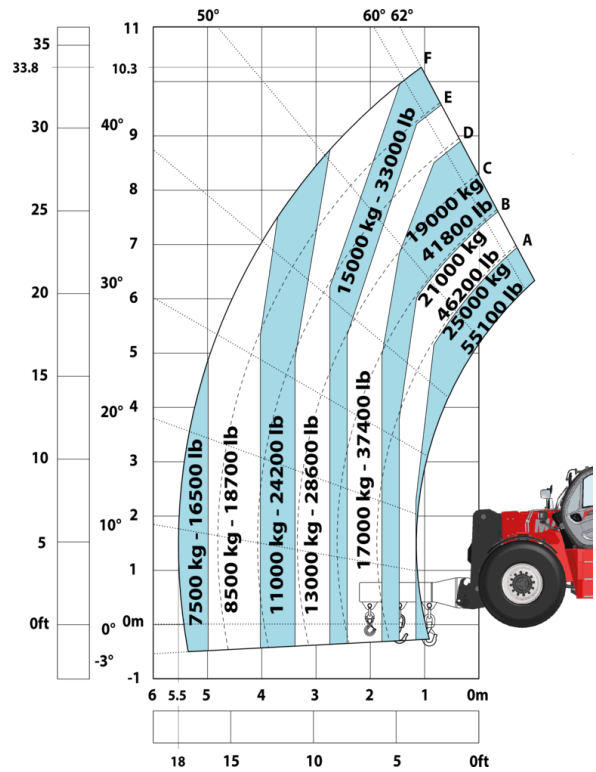

Machine on tires with underground mining platform (Metric)

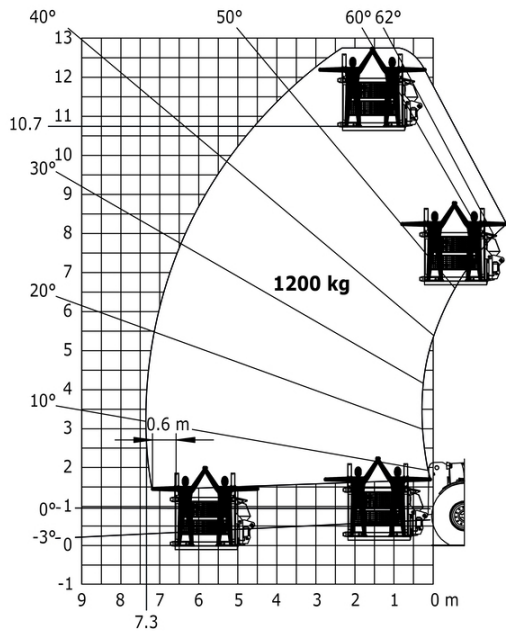

Machine on tires with tire handler TH 63 (Metric)

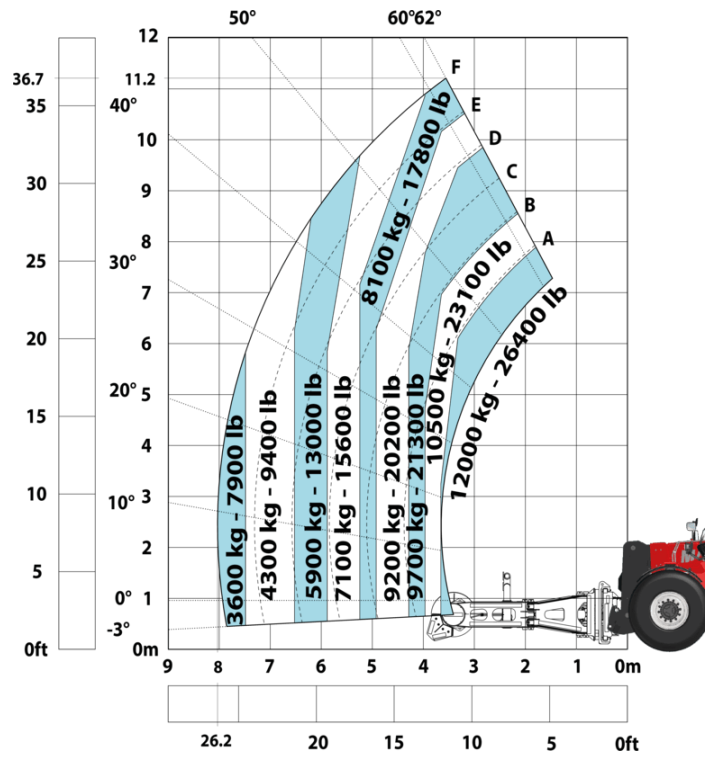

Machine on tires with cylinder handler CH 10 (Metric)

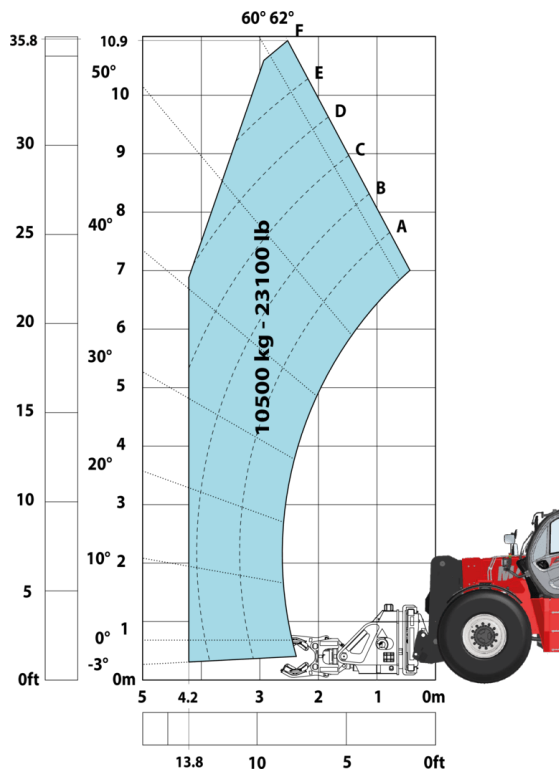

# Spécifications Mining

	MHTX 11250 Mining
<b>Lifting function</b>	
Camera in boom head with screen in cab	S
Clamp predisposition (controls from cabin)	S
Working platform predisposition with remote control	S
<b>Lighting</b>	
Brake Lights ON When Park Brake ON	S
Flat Led Rotating Beacon	S
LED Flashing Lights On Cabin (Marker Lights)	S
LED tramping lights	S
LED work lights on the boom (x2)	S
LED working lights on cab (x4 : 2 front + 2 rear)	S
<b>Motorization/Power</b>	
Exhaust fume purification system	S
Hydraulic hose sleeve burst protection	S
Radiator safety cap	S
<b>Operator station</b>	
Cabin first step at 400 mm	S
Roof and Windshield Guard	S
<b>Other options</b>	
Battery + Starter Isolators + Jump Start Receptacle	S
<b>Pneumatics</b>	
Steel mudguards	0
<b>Secondary functions</b>	
Automatic Greasing System (AGS) - chassis + boom	0
Fast fuel filling system	0
<b>Security</b>	
"Guardian Angel" System Level 1	S
360° visibility safety system	S
Boom cylinder lock	S
Electromagnetic braking system TELMA	0
Emergency steering	S
Emergency stop by safety valve	0
Emergency stop: 1 in cab, 2 on external	S
Engine compartment fire prevention kit	0
Extinguisher brackets (x3)	S
Fire suppression system	0
Fuse board protection - MHT's	S
High visibility reflective strips	S
Loose wheel nut indicators	S
Marking - Warning & Danger decals	S
Mining protection grids: right, left and back windows	0
Negative brakes on front & rear axles	S
Rear and lateral camera with cab screen	S
Rear bumper	0
Right side bumper	0
Steel Protection Guards on all working and road lights	S
System with attachments recognition (E-reco)	S
Wheel chocks	S

# Équipements

## Standard

"Guardian Angel" System Level 1  
360° visibility safety system  
Battery + Starter Isolators + Jump Start Receptacle  
Boom cylinder lock  
Brake Lights ON When Park Brake ON  
Cabin first step at 400 mm  
Camera in boom head with screen in cab  
Clamp predisposition (controls from cabin)  
Emergency steering  
Emergency stop: 1 in cab, 2 on external  
Exhaust fume purification system  
Extinguisher brackets (x3)  
Flat Led Rotating Beacon  
Fuse board protection - MHT's  
High visibility reflective strips  
Hydraulic hose sleeve burst protection  
LED Flashing Lights On Cabin (Marker Lights)  
LED tramming lights  
LED work lights on the boom (x2)  
LED working lights on cab (x4 : 2 front + 2 rear)  
Loose wheel nut indicators  
Marking - Warning & Danger decals  
Negative brakes on front & rear axles  
Radiator safety cap  
Rear and lateral camera with cab screen  
Roof and Windshield Guard  
Steel Protection Guards on all working and road lights  
System with attachments recognition (E-reco)  
Wheel chocks  
Working platform predisposition with remote control

## Optionnel

Automatic Greasing System (AGS) - chassis + boom  
Electromagnetic braking system TELMA  
Emergency stop by safety valve  
Engine compartment fire prevention kit  
Fast fuel filling system  
Fire suppression system  
Mining protection grids: right, left and back windows  
Rear bumper  
Right side bumper  
Steel mudguards

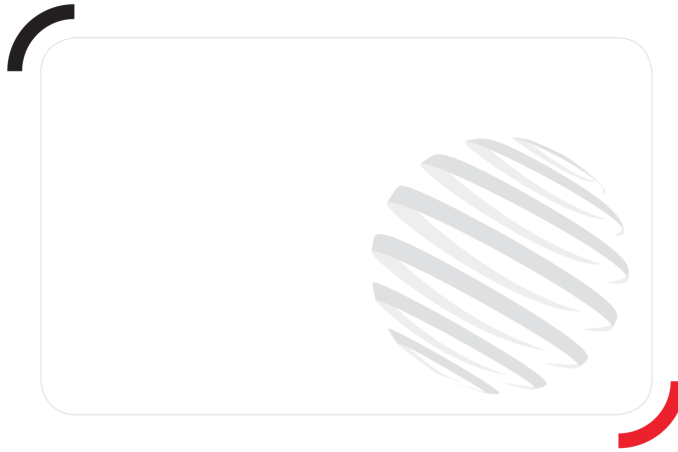

**Siège Social**

B.P. 249 - 430 rue de l'Aubinière

44150 Ancenis Cedex - France

Tel: +33 (0)2 40 09 10 11 - Fax: +33 (0)2 40 09 10 97

[www.manitou.com](http://www.manitou.com)



Cette publication présente le descriptif des versions et possibilités de configuration des produits Manitou qui peuvent différer en équipement. Les équipements présentés dans cette brochure peuvent être de série, en option, ou non disponibles suivant les versions. Manitou se réserve le droit, à tout moment et sans préavis, de modifier les spécifications décrites et représentées. Les spécifications portées n'engagent pas le constructeur. Pour plus de détails, contactez votre concessionnaire Manitou. Document non contractuel. Présentation des produits non contractuelle. Liste des spécifications non exhaustive. Les logos ainsi que l'identité visuelle de l'entreprise sont la propriété de Manitou et ne peuvent être utilisés sans autorisation. Tous droits réservés. Les photos et schémas contenus dans la présente brochure ne sont fournis qu'à des fins de consultation et à titre indicatif.

Manitou BF SA - Société anonyme à conseil d'administration - Capital social : 39 668 399 euros - 857 802 508 RCS Nantes