

Technical sheet :

MLA 3-25 H



 **MANITOU**
HANDLING YOUR WORLD

Capacities		Metric
Static tipping load with bucket (straight)		1270 kg
Static tipping load with bucket (full turn)		1115 kg
Static tipping load with forks (straight)		965 kg
Static tipping load with forks (full turn)		845 kg
Max. height of bucket pivot point	h35	2836 mm
Weight and dimensions		
Unladen weight (with forks) with 4-post canopy		2170 kg
Wheelbase	y	1650 mm
Overall cab width	b4	991 mm
Overall height with 4 posts canopy	h38	2258 mm
Dump reach - Full height	r6	479 mm
Hood Height	h40	1405 mm
Overall Operating Height - Fully Raised	h27	3696 mm
Articulation angle	a19	45 °
Maximum oscillation angle		11 °
Overall length with bucket	l16	4154 mm
Overall width less bucket	b1	1100 mm
Overall length - Less Bucket	l2	3458 mm
Rear overhang	c6	995 mm
Dump angle - Fully raised	a5	42 °
Dump Height - Fully Raised	h29	2126 mm
Maximum Rollback Angle - Fully Raised	a4	48 °
Digging Position	h32	-79 mm
Ground clearance	m4	320 mm
Clearance Radius - Front with Bucket	b18	3246 mm
Clearance Radius - Less bucket	b14	2767 mm
Ground Plane to Bucket Edge Height	h42	2655 mm
Tread width (wheel center)	b29	836 mm
Attachment Pivot Clearance		103 mm
Height from ground to axle center	m8	214 mm
Bucket Width	e1	1520 mm
Front Wheel Center to Pivot Pin	m3	669 mm
Height to Hinge Pin - Fully Raised	h28	2520 mm
Engine		
Engine brand		Perkins
Engine model		403J-17
Engine nom		Stage V
Number of cylinders		3
I.C. Engine power rating / Power		24.70 Hp / 18.40 kW
Max. torque / Engine rotation		85 Nm / 1800 rpm
Engine cooling system		Water
Transmission		
Transmission type		Hydrostatic
Number of gears (forward / reverse)		2 / 2
Max. travel speed (may vary according to applicable regulations)		20 km/h
Service brake		Hydraulic drum brake on front axle, acting on all 4 wheels
Hydraulics		
Hydraulic pump type		Gear pump
Hydraulic flow - Pressure		30 l/min / 207 bar
High-Flow Option (l/min)		30 l/min
Tank capacities		
Hydraulic oil		24 l
Fuel tank		45 l

MLA 3-25 H - Dimensional drawing

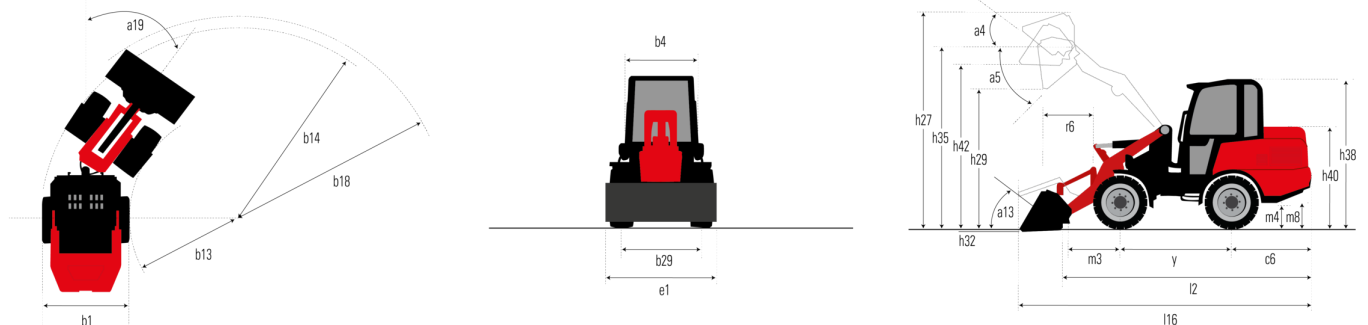

**Head Office**

B.P. 249 - 430 rue de l'Aubinière

44150 Ancenis Cedex - France

Tel: +33 (0)2 40 09 10 11 - Fax: +33 (0)2 40 09 10 97

www.manitou.com

This publication provides a description of the configuration versions and options for Manitou products, which may differ for equipment. The equipment presented in this brochure may be part of a series, as an option, or it may not be available, depending on the versions. Manitou reserves the right, at any time and without notice, to amend the specifications described and represented. The specifications provided do not bind the manufacturer. For more details, please contact your Manitou agent. This is not a contractually binding document. The presentation of the products is not contractually binding. List of specifications non-exhaustive. The logos as well as the visual identity of the company are owned by Manitou and cannot be used without authorisation. All rights reserved. The photos and diagrams contained in this brochure are only provided for consultation and information purposes.

MANITOU BF SA - Limited company with board of directors - Share capital: 39,668,399 euros - 857 802 508 RCS Nantes