

技術シート：

# MLA 4-50 H



 **MANITOU**  
HANDLING YOUR WORLD

キャバンティアー		メートル単位
バケットストレートでの静止転倒荷重		1540 kg
バケット全回転での静止転倒荷重		1355 kg
フォーク静止転倒荷重 (直進)		1175 kg
フォーク静止転倒荷重 (フルターン)		1030 kg
バケットピボットポイントの最大高さ	h35	2836 mm
仕様		
4ポストキャノピー付無負荷重量 (フォーク)		2316 kg
ホイールベース	y	1650 mm
キャブ幅	b4	991 mm
4ポストキャノピーの全高	h38	2258 mm
最大高-ダンブリーチ	r6	479 mm
フードの高さ	h40	1405 mm
全操作高さ-完全に上昇した状態	h27	3636 mm
関節角度	a19	45 °
Maximum oscillation angle		10 °
バケット付全長	l16	4279 mm
全幅レスバケット	b1	1100 mm
全長-バケット無	l2	3583 mm
リアオーバーハング	c6	1120 mm
ダンブ角度-最上昇時	a5	42 °
ダンブ高-最大伸ばし時	h29	2126 mm
最大ロールバック角度-最大延伸時	a4	48 °
地面での最大ロールバック角度	a13	50 °
掘削位置	h32	-79 mm
最低地上高	m4	320 mm
クリアランス半径-バケット付フロント	b18	3246 mm
旋回半径-バケット無	b14	2767 mm
グランドプレーンからバケットエッジの高さ	h42	2655 mm
Tread width (wheel center)	b29	836 mm
アタッチメントピボットクリアランス		103 mm
Height from ground to axle center	m8	214 mm
バケット幅	e1	1520 mm
前輪センターからピボットピンまで	m3	669 mm
ヒンジピンまでの高さ-完全に持ち上げられた状態	h28	2900 mm
エンジン		
メーカー		Perkins
エンジンモデル		403J-E17T
エンジン排出ガス規制		Stage V
シリンダー		3
定格出力 / 定格出力		48 Hp / 36 kW
最大トルク / 回転数		166 Nm / 1600 rpm
エンジンクーリングシステム		水
トランスミッション		
変速装置		ハイドロマチック
変速段数 (前方) / 変速段数 (後方)		2 / 2
最大走行速度 (適用規制によって変動)		20 km/h
制動ブレーキ		インチングブレーキ
油圧		
油圧ポンプタイプ		ギアポンプ
油圧システム-油圧		60 l/min / 207 bar
ハイフローオプション (l/min)		60 l/min
タンク容量		
作動油容量		48 l
燃料タンク容量		45 l

## MLA 4-50 H - 寸法図

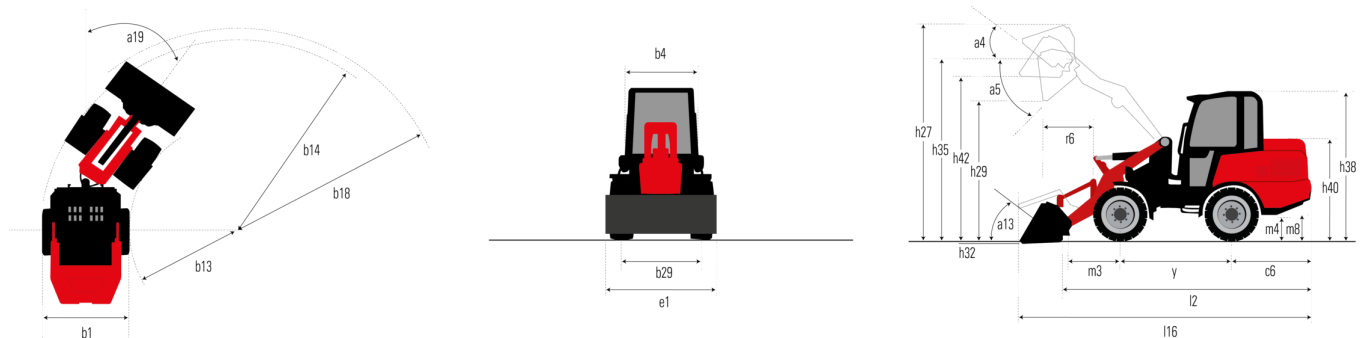



#### 本社ビル

B.P. 249 - 430 rue de l'Aubinière (オービニエール通り)

44150 Ancenis Cedex - France

電話: +33 (0)2 40 09 10 11 - ファックス: +33 (0)2 40 09 10 97

[www.manitou.com](http://www.manitou.com)



本書では、マニトウ製品の構成バージョンやオプションについて説明していますが、機器によって異なる場合があります。このパンフレットで紹介されている機器は、バージョンによってシリーズの一部であったり、オプションであったり、あるいは利用できない場合があります。Manitouは、いつでも予告なしに、記載・表現されている仕様を変更する権利を有します。提供された仕様はメーカーを拘束するものではありません。詳細につきましては、マニトウの代理店にお問い合わせください。本資料は、契約上の拘束力を有するものではありません。製品の提示は、契約上の拘束力はありません。仕様のリストは無尽蔵です。ロゴおよび会社のビジュアル・アイデンティティはManitouが所有しており、許可なく使用することはできません。すべての権利はマニトウに帰属します。このパンフレットに掲載されている写真や図は、相談や情報提供を目的としています。

MANITOU BF SA - 取締役会を有する有限会社・株式資本。39 668 399 ユーロ - 857 802 508 RCS Nantes