

Ficha técnica :

# **MLT 1041-145 PS+L**

---



 **MANITOU**  
HANDLING YOUR WORLD

Capacities		Métrico
Max. capacity	Q	4100 kg
Max. lifting height	h3	9.65 m
Max. outreach		6.50 m
Reach at max. height		1.50 m
Breakout force with bucket		5043 daN
Weight and dimensions		
Unladen weight (with forks)		9690 kg
Ground clearance	m4	0.43 m
Wheelbase	y	2.88 m
Overall length to carriage (with hitch)	l11	5.20 m
Overall length to carriage (without hitch)	l3	5.03 m
Front overhang		1.30 m
Overall width	b1	2.39 m
Overall cab width	b4	0.99 m
Overall height	h17	2.42 m
Tilt-down angle	a5	135 °
Tilt-up angle	a4	12 °
External turning radius (over tyres)	Wa1	3.74 m
Standard tires		Michelin - XMCL - 460/70 R24 159A8
Drive wheels (front / rear)		2 / 2
Steering wheels (front / rear)		2 / 2
Frame leveling corrector	a9	7 °
Performances		
Lifting		6.60 s
Lowering		4.70 s
Extension		9.50 s
Retraction		6.90 s
Crowd		3.70 s
Dump		2.80 s
Engine		
Engine brand		Yanmar
Engine norm		Stage V / Tier 4 Final
Engine model		4TN107FHT-5SMUF
Number of cylinders - Capacity of cylinders		4 - 4567 cm <sup>3</sup>
I.C. Engine power rating / Power		141 Hp / 105 kW
Max. torque / Engine rotation		602 Nm @1500 rpm
Drawbar pull (Laden)		9130 daN
Reversible fan		Standard
Engine cooling system		4 radiators (water + intercooler + hydraulic oil + transmission oil)
Transmission		
Transmission type		Torque converter with powershift gearbox
Gearbox		M-Shift
Number of gears (forward / reverse)		5 / 3
Max. travel speed (may vary according to applicable regulations)		40 km/h
Differential lock		Limited slip differential on front and rear axles
Parking brake		Automatic negative parking brake
Service brake		Oil-immersed multi-discs braking on front & rear axles
Hydraulics		
Hydraulic pump type		Variable displacement pump
Hydraulic flow - Pressure		200 l/min - 270 bar
Flow sharing distributor		Standard
Tank capacities		
Hydraulic tank capacity		141 l
Fuel tank		142 l
Diesel Exhaust fluid (AdBlue® type)		21.50 l
Noise and vibration		
Noise at driving position (LpA) tested following NF EN 12053 nom		69 dB
Noise to environment (LwA)		105 dB
Vibration on hands/arms		< 2.50 m/s <sup>2</sup>
Miscellaneous		
Tractor homologation		Tractor homologation
Safety cab homologation		Cabin ROPS - FOPS level 2
Controls		JSM

## Optional tires tab

	Overall height	Overall width
ALLIANCE - A580 - 460/70 R24 159A8	2.53 m	2.38 m
ALLIANCE - A585 - 460/70 R24 159A8	2.53 m	2.39 m
MICHELIN - BIBLOAD - 460/70 R24 159A8	2.52 m	2.39 m
MICHELIN - BIBLOAD - 500/70 R24 164A8	2.56 m	2.42 m
MICHELIN - XMCL - 460/70 R24 159A8	2.53 m	2.39 m
MICHELIN - XMCL - 500/70 R24 164A8	2.55 m	2.43 m
TRELLEBORG - TH400 - 460/70 R24 159A8	2.52 m	2.39 m
TRELLEBORG - TH400 - 500/70 R24 164A8	2.55 m	5.42 m
TRELLEBORG - TH500 - 460/70 R24 159A8	2.53 m	2.41 m
VREDESTEIN - ENDURION - 460/70 R24 159A8	2.54 m	2.40 m
VREDESTEIN - ENDURION - 500/70 R24 164A8	2.56 m	2.44 m

## MLT 1041-145 PS+L - Diagrama dimensional

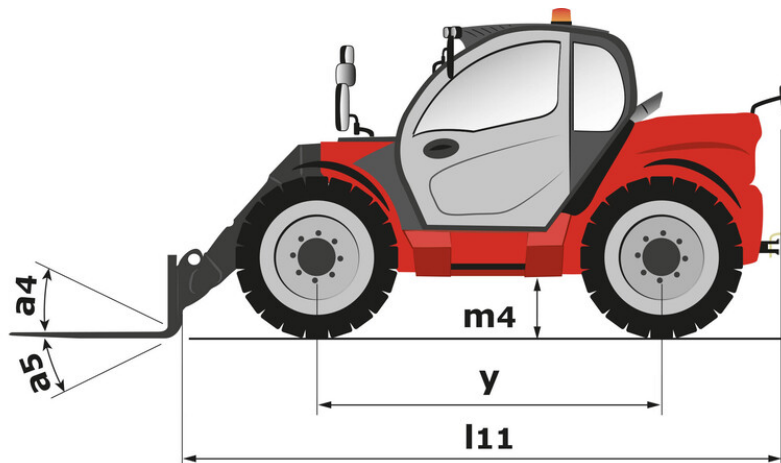

## MLT 1041-145 PS+L - Diagramas de carga

Machine on tires with forks Metric

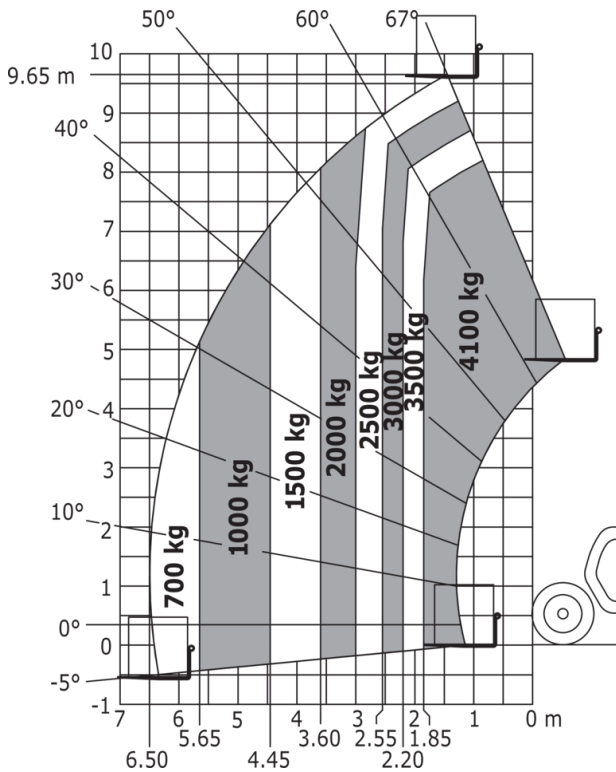



 **MANITOU**  
**HANDLING YOUR WORLD**

**Oficina Central**

B.P. 249 - 430 rue de l'Aubinière

44150 Ancenis Cedex - Francia

Tel.: 00 33 (0)2 40 09 10 11 - Fax: 00 33 (0)2 40 09 10 97

[www.manitou.com](http://www.manitou.com)



Esta publicación describe las versiones y posibilidades de configuración de los productos Manitou que puedan diferir en equipamiento. Los equipamientos presentados en este folleto pueden ser de serie, opcionales o no estar disponibles en algunas versiones. Manitou se reserva el derecho, en cualquier momento y sin previo aviso, de modificar las especificaciones descritas y representadas. Las especificaciones aportadas no comprometen al fabricante. Para más información, póngase en contacto con su concesionario Manitou. Documento no contractual. Presentación de los productos no contractual. Lista de especificaciones no exhaustiva. Los logos y la identidad visual de la empresa son propiedad de Manitou y no pueden ser utilizados sin autorización. Todos los derechos reservados. Las fotos y los esquemas contenidos en este folleto se ofrecen para consulta y a título indicativo solamente.

Manitou BF SA - Sociedad anónima con Consejo de Administración - Capital social: 39 668 399 euros - 857 802 508 RCS Nantes