

Fiche technique :

MLT-X 1041-145 PS+L



 **MANITOU**
HANDLING YOUR WORLD

Capacities		Métrique
Max. capacity	Q	4100 kg
Max. lifting height	h3	9.65 m
Max. outreach		6.50 m
Reach at max. height		1.50 m
Breakout force with bucket		5043 daN
Weight and dimensions		
Unladen weight (with forks)		9690 kg
Ground clearance	m4	0.43 m
Wheelbase	y	2.88 m
Overall length to carriage (with hitch)	l11	5.20 m
Overall length to carriage (without hitch)	l3	5.03 m
Front overhang		1.30 m
Overall width	b1	2.39 m
Overall cab width	b4	0.99 m
Overall height	h17	2.42 m
Tilt-down angle	a5	135 °
Tilt-up angle	a4	12 °
External turning radius (over tyres)	Wa1	3.74 m
Standard tires		Michelin - XMCL - 460/70 R24 159A8
Drive wheels (front / rear)		2 / 2
Steering wheels (front / rear)		2 / 2
Frame leveling corrector	a9	7 °
Performances		
Lifting		6.60 s
Lowering		4.70 s
Extension		9.50 s
Retraction		6.90 s
Crowd		3.70 s
Dump		2.80 s
Engine		
Engine brand		Yanmar
Engine norm		Stage IIIA
Max. fuel sulphur content		1000 ppm
Engine model		4TN107HT-5SMUF
Number of cylinders - Capacity of cylinders		4 - 4567 cm ³
I.C. Engine power rating / Power		141 Hp / 105 kW
Max. torque / Engine rotation		602 Nm @1500 rpm
Drawbar pull (Laden)		9130 daN
Reversible fan		Standard
Engine cooling system		4 radiators (water + intercooler + hydraulic oil + transmission oil)
Transmission		
Transmission type		Torque converter with powershift gearbox
Gearbox		M-Shift
Number of gears (forward / reverse)		5 / 3
Max. travel speed (may vary according to applicable regulations)		40 km/h
Differential lock		Limited slip differential on front and rear axles
Parking brake		Automatic negative parking brake
Service brake		Oil-immersed multi-discs braking on front & rear axles
Hydraulics		
Hydraulic pump type		Variable displacement pump
Hydraulic flow - Pressure		200 l/min - 270 bar
Flow sharing distributor		Standard
Tank capacities		
Hydraulic tank capacity		141 l
Fuel tank		142 l
Noise and vibration		
Noise at driving position (LpA) tested following NF EN 12053 nom		69 dB
Noise to environment (LwA)		105 dB
Vibration on hands/arms		< 2.50 m/s ²
Miscellaneous		
Tractor homologation		Tractor homologation
Safety cab homologation		Cabin ROPS - FOPS level 2
Controls		JSM

Optional tires tab

	Overall height	Overall width
ALLIANCE - A580 - 460/70 R24 159A8	-	-
ALLIANCE - A585 - 460/70 R24 159A8	-	-
MICHELIN - BIBLOAD - 460/70 R24 159A8	-	-
MICHELIN - BIBLOAD - 500/70 R24 164A8	-	-
MICHELIN - XMCL - 500/70 R24 164A8	-	-
TRELLEBORG - TH400 - 460/70 R24 159A8	-	-
TRELLEBORG - TH400 - 500/70 R24 164A8	-	-
TRELLEBORG - TH500 - 460/70 R24 159A8	-	-
VREDESTEIN - ENDURION - 460/70 R24 159A8	-	-
VREDESTEIN - ENDURION - 500/70 R24 164A8	-	-

MLT-X 1041-145 PS+L - Schémas d'encombrement

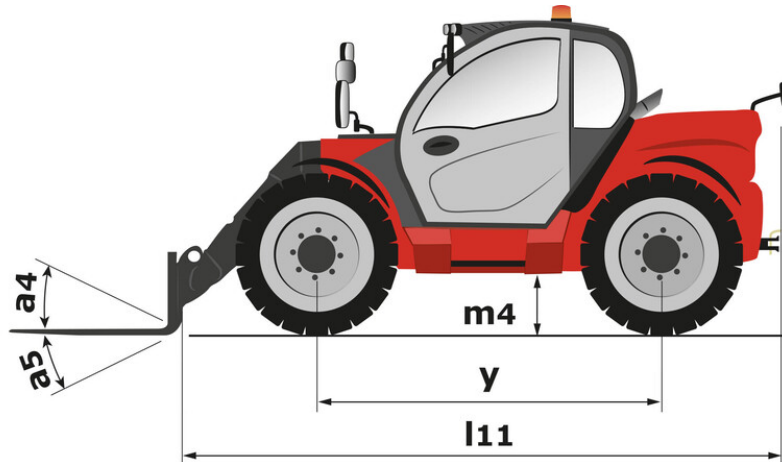

MLT-X 1041-145 PS+L - Abaques

Machine on tires with forks Metric

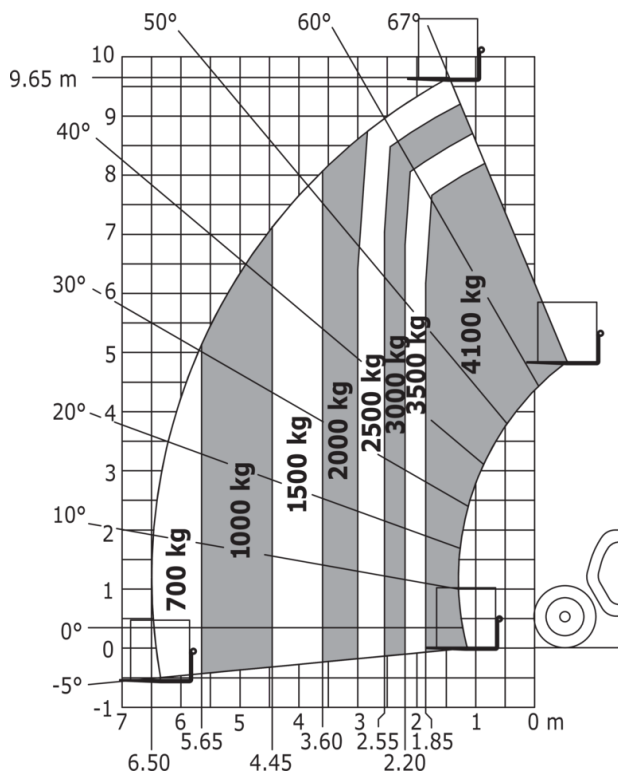



Siège Social

B.P. 249 - 430 rue de l'Aubinière
44150 Ancenis Cedex - France

Tel: +33 (0)2 40 09 10 11 - Fax: +33 (0)2 40 09 10 97

www.manitou.com



Cette publication présente le descriptif des versions et possibilités de configuration des produits Manitou qui peuvent différer en équipement. Les équipements présentés dans cette brochure peuvent être de série, en option, ou non disponibles suivant les versions. Manitou se réserve le droit, à tout moment et sans préavis, de modifier les spécifications décrites et représentées. Les spécifications portées n'engagent pas le constructeur. Pour plus de détails, contactez votre concessionnaire Manitou. Document non contractuel. Présentation des produits non contractuelle. Liste des spécifications non exhaustive. Les logos ainsi que l'identité visuelle de l'entreprise sont la propriété de Manitou et ne peuvent être utilisés sans autorisation. Tous droits réservés. Les photos et schémas contenus dans la présente brochure ne sont fournis qu'à des fins de consultation et à titre indicatif.

Manitou BF SA - Société anonyme à conseil d'administration - Capital social : 39 668 399 euros - 857 802 508 RCS Nantes