

Ficha técnica :

MT-X 1033 A MINING



Capacidad		Métrico
Capacidad de elevación máx.		3300 kg
Altura de elevación máx		9.98 m
Alcance máx		7.15 m
Fuerza de arranque con cuchara		5330 daN
Peso y dimensión		
Longitud total al tablero de horquillas	l11	4.93 m
Longitud hasta cara de las horquillas	l2	4.93 m
Anchura total	b1	2.25 m
Altura total	h17	2.30 m
Distancia entre ejes	y	2.69 m
Distancia al suelo	m4	0.44 m
Anchura total de la cabina	b4	0.89 m
Ángulo de volteo	a4	12 °
Ángulo de vertido	a5	114 °
Radio de giro exterior	Wa1	3.66 m
Peso sin carga		8570 kg
Equipamientos de rueda		Neumático
Modelos de los neumáticos		Alliance 400/80 - 24 - 162A8
Largo de las horquillas / Anchura de horquillas / Sección de horquillas	l / e / s	1200 mm x 125 mm x 45 mm
Rendimiento		
Subida		6.70 s
Bajada		5.40 s
Salida del telescopio		13.60 s
Retracción		8.70 s
Cavado		2.70 s
Vertido		2.30 s
Motor		
Marca		Perkins
Modelo de motor		1104D-44 TA
Nº de cilindros / Capacidad de cilindros		4 - 4400 cm³
Potencia del motor I.C. - Potencia		101 Hp / 74.50 kW
Par máx. / Rotación del par de motor		410 Nm @ 1400 rpm
Esfuerzo de tracción		9100 daN
Transmisión		
Tipo de transmisión		Convertidor de par
Número de marchas (hacia delante / atrás)		4 / 4
Max. travel speed		27 km/h
Velocidad de desplazamiento máx. (km/h) (puede variar según la normativa aplicable)		27 km/h
Freno de aparcamiento		Manual
Freno de servicio		Multidisco bañado en aceite en los ejes delantero y trasero
Hidráulico		
Tipo de bomba		Bomba de engranajes
Caudal hidráulico / Presión hidráulica		106 l/min-250 bar
Capacidad del tanque		
Aceite de motor		11 l
Aceite hidráulico		128 l
Capacidad del depósito de carburante		120 l
Ruido y vibración		
Ruido en el puesto de conducción (LpA)		76 dB
Ruido en el entorno (LwA)		104 dB
Vibraciones en manos/brazos		< 2.50 m/s²
Vaños		
Ruedas directrices (delanteras / traseras)		2 / 2
Ruedas motrices (delanteras / traseras)		2 / 2
Seguridad / Certificación de cabina		Standard EN 15000 / Cabina ROPS - FOPS nivel 2
Mandos		JSM

MT-X 1033 A Mining - Diagramas de carga

Máquina sobre neumáticos con horquillas

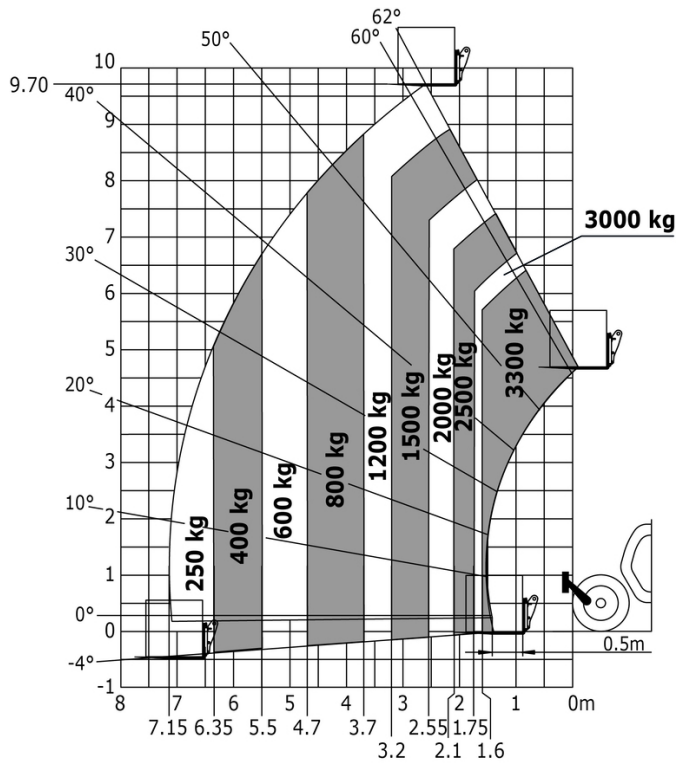

Rotación sobre estabilizadores bajados, con horquillas



Máquina sobre estabilizadores con cesta para túneles (Metric)



Máquina sobre estabilizadores con cesta minera subterránea (Metric)



Máquina sobre neumáticos con manipulador de neumáticos delgado TH 33 (Metric)

Máquina sobre estabilizadores con manipulador de neumáticos delgado TH 33 (Metric)

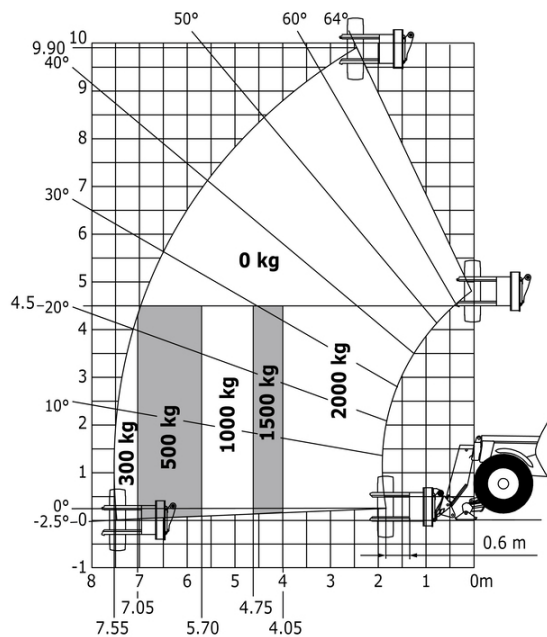
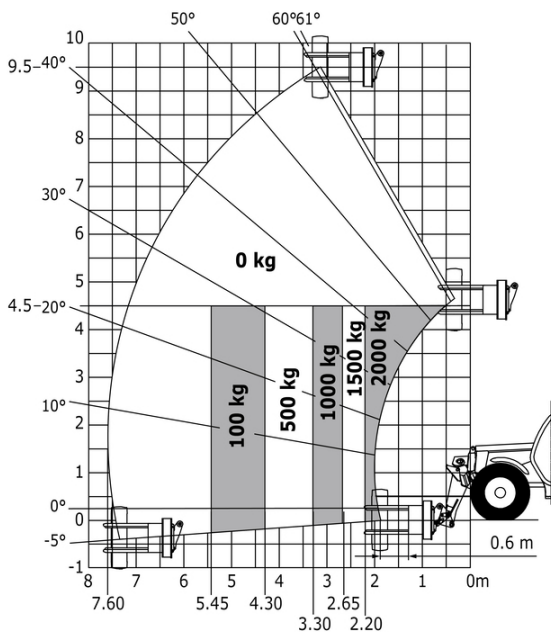

Mining Specifications

	MTX 1033 A Mining
Funciones secundarias	
Sistema de engrase automático (AGS) - Chasis + pluma	O
Función de elevación	
Predisposición de la plataforma de trabajo con control remoto	E
Predisposición de pinza (mandos desde la cabina)	O
Suspensión de pluma Comfort Ride Control (CRC)	O
Iluminación	
Baliza Led Plana Giratoria	E
Luces de freno encendida cuando freno de mano metido	E
Luces de trabajo LED - En la parte superior de la pluma (parte fija) (x2)	E
Luces de trabajo LED en la cabina (x4 : 2 frontales + 2 trasero)	E
Luces direccionales LED (Rojo/verde)	E
Luces led intermitentes en la cabina	E
Motorización/Potencia	
Funda de protección mangueras hidráulicas	E
Prefiltro ciclónico metálico	E
Sistema purificador de gases de escape	E
Tapa radiador	E
Otras opciones	
Aislador Batería/arranque + Jump Start en exterior con carcasa resistente a la intemperie	E
Seguridad	
Audio warning on reverse movements (lynx noise)	E
Bloqueo cilindro flecha	E
Caja de fusibles reforzada con disyuntores - MT	E
Cinta reflectante	E
Cúñas de la rueda	E
Dirección de emergencia	E
Fire extinguisher	E
Frenos negativos en eje delantero y trasero	E
Indicadores de tuerca de rueda flojos	E
Marcas - pegatinas de advertencia y de peligro	E
Parada de emergencia: 1 en la cabina, 2 exterior	E
Parilla de protección del parabrisa	E
Rejillas de protección : vidrios derecha, izquierda y trasera	E
Sistema "Guardian Angel" Nivel 1	E
Sistema Supresión incendio	O
Sistema de camera lateral y trasera con pantalla en la cabina	E

Equipamiento

Estándar

Aislador Batería/arranque + Jump Start en exterior con carcasa resistente a la intemperie

Audio warning on reverse movements (lynx noise)

Baliza Led Plana Giratoria

Bloqueo cilindro flecha

Caja de fusibles reforzada con disyuntores - MT

Cinta reflectante

Cuñas de la rueda

Dirección de emergencia

Fire extinguisher

Frenos negativos en eje delantero y trasero

Funda de protección mangueras hidráulicas

Indicadores de tuerca de rueda flojos

Luces de freno encendida cuando freno de mano metido

Luces de trabajo LED - En la parte superior de la pluma (parte fija) (x2)

Luces de trabajo LED en la cabina (x4 : 2 frontales + 2 trasero)

Luces direccionales LED (Rojo/verde)

Luces led intermitentes en la cabina

Marcas - pegatinas de advertencia y de peligro

Parada de emergencia: 1 en la cabina, 2 exterior

Parilla de protección del parabrisa

Predisposición de la plataforma de trabajo con control remoto

Prefiltro ciclónico metálico

Rejillas de protección : vidrios derecha, izquierda y trasera

Sistema "Guardian Angel" Nivel 1

Sistema de camera lateral y trasera con pantalla en la cabina

Sistema purificador de gases de escape

Tapa radiador

Opcional

Predisposición de pinza (mandos desde la cabina)

Sistema Supresión incendio

Sistema de engrase automático (AGS) - Chasis + pluma

Suspensión de pluma Comfort Ride Control (CRC)



Oficina Central

B.P. 249 - 430 rue de l'Aubinière

44150 Ancenis Cedex - Francia

Tel.: 00 33 (0)2 40 09 10 11 - Fax: 00 33 (0)2 40 09 10 97

www.manitou.com



Esta publicación describe las versiones y posibilidades de configuración de los productos Manitou que puedan diferir en equipamiento. Los equipamientos presentados en este folleto pueden ser de serie, opcionales o no estar disponibles en algunas versiones. Manitou se reserva el derecho, en cualquier momento y sin previo aviso, de modificar las especificaciones descritas y representadas. Las especificaciones aportadas no comprometen al fabricante. Para más información, póngase en contacto con su concesionario Manitou. Documento no contractual. Presentación de los productos no contractual. Lista de especificaciones no exhaustiva. Los logos y la identidad visual de la empresa son propiedad de Manitou y no pueden ser utilizados sin autorización. Todos los derechos reservados. Las fotos y los esquemas contenidos en este folleto se ofrecen para consulta y a título indicativo solamente.

Manitou BF SA - Sociedad anónima con Consejo de Administración - Capital social: 39 668 399 euros - 857 802 508 RCS Nantes