

Technical sheet :

MT-X 1033 MINING



 **MANITOU**
HANDLING YOUR WORLD

Capacities		Metric
Max. capacity		3300 kg
Max. lifting height		9.98 m
Max. outreach		7.15 m
Breakout force with bucket		5330 daN
Weight and dimensions		
Overall length to carriage	l11	4.93 m
Length to face of forks	l2	4.93 m
Overall width	b1	2.25 m
Overall height	h17	2.30 m
Wheelbase	y	2.69 m
Ground clearance	m4	0.44 m
Overall cab width	b4	0.89 m
Tilt-up angle	a4	12 °
Tilt-down angle	a5	114 °
External turning radius (over tyres)	Wa1	3.66 m
Unladen weight (with forks)		7745 kg
Overall weight		7745 kg
Tires type		Pneumatic
Standard tires		Alliance 400/80 - 24 - 162A8
Forks length / width / section	l / e / s	1200 mm x 125 mm x 45 mm
Performances		
Lifting		6.70 s
Lowering		5.40 s
Extension		13.60 s
Retraction		8.70 s
Crowd		2.70 s
Dump		2.30 s
Engine		
Engine brand		Perkins
Engine model		1104D-44 TA
Number of cylinders / Capacity of cylinders		4 - 4400 cm³
I.C. Engine power rating - Power		101 Hp / 74.50 kW
Max. torque / Engine rotation		410 Nm @ 1400 rpm
Drawbar pull (Laden)		9100 daN
Transmission		
Transmission type		Torque converter
Number of gears (forward / reverse)		4 / 4
Max. travel speed		27 km/h
Max. travel speed (may vary according to applicable regulations)		27 km/h
Parking brake		Manual
Service brake		Oil-immersed multi-discs on front & rear axles
Hydraulics		
Hydraulic pump type		Gear pump
Hydraulic flow / Pressure		106 l/min-250 bar
Tank capacities		
Engine oil		11 l
Hydraulic oil		128 l
Fuel tank		120 l
Noise and vibration		
Noise at driving position (LpA)		76 dB
Noise to environment (LWA)		104 dB
Vibration on hands/arms		< 2.50 m/s²
Miscellaneous		
Steering wheels (front / rear)		2 / 2
Drive wheels (front / rear)		2 / 2
Safety / Cab certification		Standard EN 15000 / Cabin ROPS - FOPS level 2
Controls		JSM

MT-X 1033 Mining - Load chart

Machine on tires with forks Metric



Machine on lowered stabilisers with forks Metric



Machine on tires with tire handler TH 33 (Metric)



Machine on lowered stabilisers with tyre handler TH 33 (Metric)

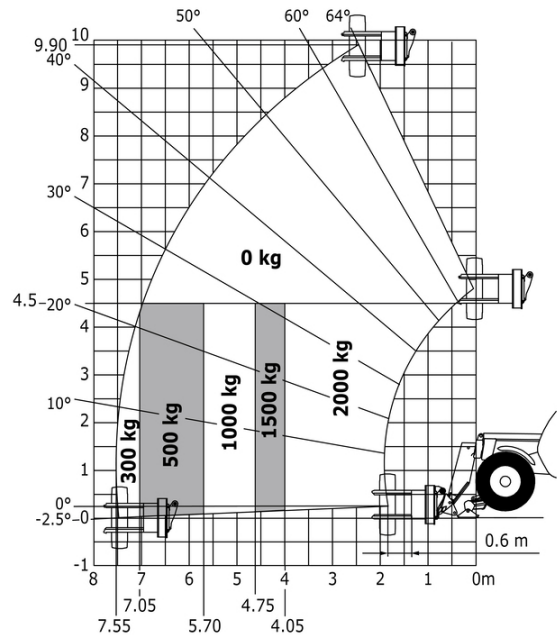

Mining Specifications

	MT-X 1033 Mining
Lifting function	
Clamp predisposition (controls from cabin)	0
Lighting	
Brake Lights ON When Park Brake ON	S
Flat Led Rotating Beacon	S
LED Flashing Lights On Cabin (Marker Lights)	S
LED traming lights	S
LED work lights on the boom (x2)	S
LED working lights on cab (x4 : 2 front + 2 rear)	S
Motorization/Power	
Exhaust fume purification system	S
Hydraulic hose sleeve burst protection	S
Metal cyclonic prefilter	S
Radiator safety cap	S
Other options	
Battery + Starter Isolators + Jump Start Receptacle	S
Secondary functions	
Automatic Greasing System (AGS) - chassis + boom	0
Security	
"Guardian Angel" System Level 1	S
Audio warning on reverse movements (lynx noise)	S
Boom cylinder lock	S
Emergency stop: 1 in cab, 2 on external	S
Fire extinguisher	S
Fire suppression system	0
Fuse board protection - MT's	S
High visibility reflective strips	S
Loose wheel nut indicators	S
Marking - Warning & Danger decals	S
Mining protection grids: right, left and back windows	S
Negative brakes on front & rear axles	S
Rear and lateral camera with cab screen	S
Wheel chocks	S
Windshield protection grid	S

Equipment

Standard	
"Guardian Angel" System Level 1	
Audio warning on reverse movements (lynx noise)	
Battery + Starter Isolators + Jump Start Receptacle	
Boom cylinder lock	
Brake Lights ON When Park Brake ON	
Emergency stop: 1 in cab, 2 on external	
Exhaust fume purification system	
Fire extinguisher	
Flat Led Rotating Beacon	
Fuse board protection - MT's	
High visibility reflective strips	
Hydraulic hose sleeve burst protection	
LED Flashing Lights On Cabin (Marker Lights)	
LED traming lights	
LED work lights on the boom (x2)	
LED working lights on cab (x4 : 2 front + 2 rear)	
Loose wheel nut indicators	
Marking - Warning & Danger decals	
Metal cyclonic prefilter	
Mining protection grids: right, left and back windows	
Negative brakes on front & rear axles	
Radiator safety cap	
Rear and lateral camera with cab screen	
Wheel chocks	
Windshield protection grid	
Optional	
Automatic Greasing System (AGS) - chassis + boom	
Clamp predisposition (controls from cabin)	
Fire suppression system	



Head Office

B.P. 249 - 430 rue de l'Aubinière

44150 Ancenis Cedex - France

Tel: +33 (0)2 40 09 10 11 - Fax: +33 (0)2 40 09 10 97

www.manitou.com



This publication provides a description of the configuration versions and options for Manitou products, which may differ for equipment. The equipment presented in this brochure may be part of a series, as an option, or it may not be available, depending on the versions. Manitou reserves the right, at any time and without notice, to amend the specifications described and represented. The specifications provided do not bind the manufacturer. For more details, please contact your Manitou agent. This is not a contractually binding document. The presentation of the products is not contractually binding. List of specifications non-exhaustive. The logos as well as the visual identity of the company are owned by Manitou and cannot be used without authorisation. All rights reserved. The photos and diagrams contained in this brochure are only provided for consultation and information purposes.

MANITOU BF SA - Limited company with board of directors - Share capital: 39,668,399 euros - 857 802 508 RCS Nantes