

Ficha técnica :

MT-X 420 H



Capacities		Métrico
Max. capacity		2000 kg
Max. lifting height		4.35 m
Max. outreach		2.65 m
Breakout force with bucket		1886 daN
Weight and dimensions		
Overall length to carriage	l11	3.58 m
Overall width	b1	1.49 m
Overall height	h17	1.97 m
Wheelbase	y	2.13 m
Ground clearance	m4	0.24 m
Overall cab width	b4	0.79 m
Tilt-up angle	a4	12 °
Tilt-down angle	a5	116 °
External turning radius (over tyres)	Wa1	2.98 m
Unladen weight (with forks)		4190 kg
Overall weight		4260 kg
Tires type		Pneumatic
Forks length / width / section	l / e / s	1200 mm x 125 mm x 45 mm
Performances		
Lifting		5 s
Lowering		3.50 s
Extension		4.80 s
Retraction		3 s
Crowd		3.30 s
Dump		2.70 s
Engine		
Engine brand		Kubota
Engine norm		Stage IIIA
Max. fuel sulphur content		500 ppm
Engine model		V2607
Number of cylinders / Capacity of cylinders		4 - 2615 cm³
I.C. Engine power rating - Power		49 Hp / 36 kW
Max. torque / Engine rotation		170 Nm @ 1600 rpm
Drawbar pull (Laden)		2850 daN
Transmission		
Transmission type		Hydrostatic
Number of gears (forward / reverse)		2 / 2
Max. travel speed		25 km/h
Max. travel speed (may vary according to applicable regulations)		25 km/h
Parking brake		Automatic Negative Hand-brake
Service brake		Disk brake on the cadran shaft
Hydraulics		
Hydraulic pump type		Gear pump
Hydraulic flow / Pressure		78 l/min-235 bar
Tank capacities		
Engine oil		10.20 l
Hydraulic oil		70 l
Fuel tank		60 l
Noise and vibration		
Noise at driving position (LpA)		76 dB
Noise to environment (LWA)		104 dB
Vibration on hands/arms		< 2.50 m/s²
Miscellaneous		
Steering wheels (front / rear)		2 / 2
Drive wheels (front / rear)		2 / 2
Safety / Safety cab homologation		Standard EN 15000 / ROPS - FOPS cab (level 1)
Controls		JSM

MT-X 420 H - Diagrama dimensional

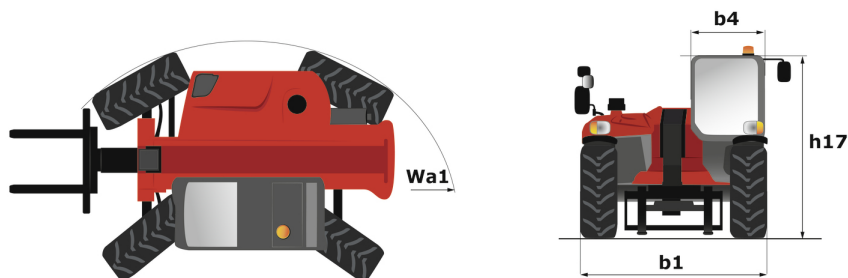

MT-X 420 H - Diagramas de carga

Machine on tires with forks Metric

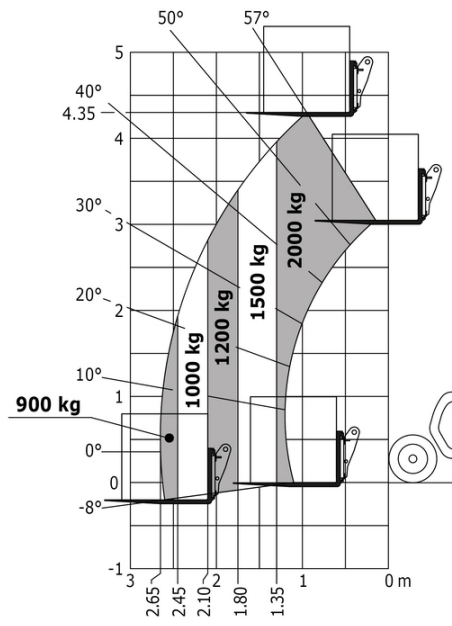



Oficina Central

B.P. 249 - 430 rue de l'Aubinière

44150 Ancenis Cedex - Francia

Tel.: 00 33 (0)2 40 09 10 11 - Fax: 00 33 (0)2 40 09 10 97

www.manitou.com



Esta publicación describe las versiones y posibilidades de configuración de los productos Manitou que puedan diferir en equipamiento. Los equipamientos presentados en este folleto pueden ser de serie, opcionales o no estar disponibles en algunas versiones. Manitou se reserva el derecho, en cualquier momento y sin previo aviso, de modificar las especificaciones descritas y representadas. Las especificaciones aportadas no comprometen al fabricante. Para más información, póngase en contacto con su concesionario Manitou. Documento no contractual. Presentación de los productos no contractual. Lista de especificaciones no exhaustiva. Los logos y la identidad visual de la empresa son propiedad de Manitou y no pueden ser utilizados sin autorización. Todos los derechos reservados. Las fotos y los esquemas contenidos en este folleto se ofrecen para consulta y a título indicativo solamente.

Manitou BF SA - Sociedad anónima con Consejo de Administración - Capital social: 39 668 399 euros - 857 802 508 RCS Nantes