

Ficha técnica :

# MT-X 733 MINING



Capacities		Métrico
Max. capacity		3300 kg
Max. lifting height		6.90 m
Max. outreach		3.90 m
Breakout force with bucket		7400 daN
Weight and dimensions		
Overall length to carriage	l11	4.74 m
Length to face of forks	l2	4.76 m
Overall width	b1	2.26 m
Overall height	h17	2.30 m
Wheelbase	y	2.81 m
Ground clearance	m4	0.45 m
Overall cab width	b4	0.89 m
Tilt-up angle	a4	12 °
Tilt-down angle	a5	114 °
External turning radius (over tyres)	Wa1	3.80 m
Unladen weight (with forks)		6620 kg
Overall weight		6620 kg
Tires type		Pneumatic
Standard tires		Alliance 400/80 - 24 - 162A8
Forks length / width / section	l / e / s	1200 mm x 125 mm x 45 mm
Performances		
Lifting		7.20 s
Lowering		5.50 s
Extension		6.50 s
Retraction		5.40 s
Crowd		2.90 s
Dump		2.80 s
Engine		
Engine brand		Perkins
Engine norm		Stage IIIA
Engine model		1104D-44 T
Number of cylinders / Capacity of cylinders		4 - 4400 cm <sup>3</sup>
I.C. Engine power rating - Power		95 Hp / 70 kW
Max. torque / Engine rotation		392 Nm @ 1400 rpm
Drawbar pull (Laden)		9000 daN
Transmission		
Transmission type		Torque converter
Number of gears (forward / reverse)		3 / 3
Max. travel speed		15 km/h
Parking brake		Manual
Service brake		Oil-immersed multi-discs braking on front & rear axles
Hydraulics		
Hydraulic pump type		Gear pump
Hydraulic flow / Pressure		104 l/min-250 bar
Tank capacities		
Engine oil		10 l
Hydraulic oil		128 l
Fuel tank		120 l
Noise and vibration		
Noise at driving position (LpA)		78 dB
Noise to environment (LWA)		104 dB
Vibration on hands/arms		< 2.50 m/s <sup>2</sup>
Miscellaneous		
Steering wheels (front / rear)		2 / 2
Drive wheels (front / rear)		2 / 2
Safety / Safety cab homologation		Standard EN 15000 / Cabin ROPS - FOPS level 2
Controls		JSM

## MT-X 733 Mining - Diagramas de carga

Machine on tires with forks Metric

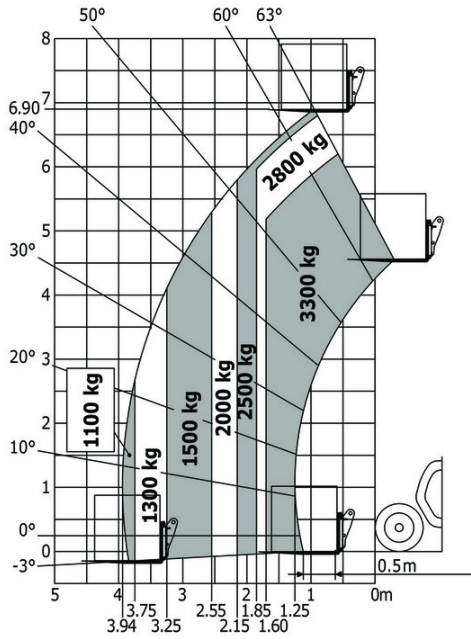

Machine on tires with tire handler TH 33 (Metric)



## Mining Specifications

	MTX 733 Mining
<b>Lifting function</b>	
Clamp predisposition (controls from cabin)	O
<b>Lighting</b>	
Brake Lights ON When Park Brake ON	E
Flat Led Rotating Beacon	E
LED Flashing Lights On Cabin (Marker Lights)	E
LED tramming lights	E
LED work lights on the boom (x2)	E
LED working lights on cab (x4 : 2 front + 2 rear)	E
<b>Motorization/Power</b>	
Exhaust fume purification system	E
Hydraulic hose sleeve burst protection	E
Metal cyclonic prefilter	E
Radiator safety cap	E
<b>Other options</b>	
Battery + Starter Isolators + Jump Start Receptacle	E
<b>Secondary functions</b>	
Automatic Greasing System (AGS) - chassis + boom	O
<b>Security</b>	
"Guardian Angel" System Level 1	E
Audio warning on reverse movements (lynx noise)	E
Boom cylinder lock	E
Emergency stop: 1 in cab, 2 on external	E
Fire extinguisher	E
Fire suppression system	O
Fuse board protection - MT's	E
High visibility reflective strips	E
Loose wheel nut indicators	E
Marking - Warning & Danger decals	E
Mining protection grids: right, left and back windows	E
Negative brakes on front & rear axles	E
Rear and lateral camera with cab screen	E
Wheel chocks	E
Windshield protection grid	E



**Oficina Central**

B.P. 249 - 430 rue de l'Aubinière

44150 Ancenis Cedex - Francia

Tel.: 00 33 (0)2 40 09 10 11 - Fax: 00 33 (0)2 40 09 10 97

[www.manitou.com](http://www.manitou.com)



Esta publicación describe las versiones y posibilidades de configuración de los productos Manitou que puedan diferir en equipamiento. Los equipamientos presentados en este folleto pueden ser de serie, opcionales o no estar disponibles en algunas versiones. Manitou se reserva el derecho, en cualquier momento y sin previo aviso, de modificar las especificaciones descritas y representadas. Las especificaciones aportadas no comprometen al fabricante. Para más información, póngase en contacto con su concesionario Manitou. Documento no contractual. Presentación de los productos no contractual. Lista de especificaciones no exhaustiva. Los logos y la identidad visual de la empresa son propiedad de Manitou y no pueden ser utilizados sin autorización. Todos los derechos reservados. Las fotos y los esquemas contenidos en este folleto se ofrecen para consulta y a título indicativo solamente.

Manitou BF SA - Sociedad anónima con Consejo de Administración - Capital social: 39 668 399 euros - 857 802 508 RCS Nantes