

Technical sheet :

STACKY 10 D28



 **MANITOU**
HANDLING YOUR WORLD

Technical characteristics		Metric	
1.1	Manufacturer		Manitou
1.2	Model Name		Stacky 10 D28
1.3	Power source		Electrical
1.4	Operator type		Pedestrian
1.5	Max. capacity	Q	1000 kg
1.6	Load center of gravity	c	600 mm
1.8	Load distance, centre of drive axle to fork	x	653 mm
1.9	Wheelbase	y	1160 mm
Weight			
2.1	Overall weight without tools		620 kg
Wheels			
3.1	Tires type		Polyurethane
3.5.2	Number of drive wheels - Size of drive wheels		1 x 200x80
3.3	Number of load wheels - Size of load wheels		2 x 78x78
3.4	Number of castor wheels		1
3.4	Number of stabilizer wheels / Size of the stabilizer wheels		2 x 125x50
3.5	Number of front wheels / rear wheels		1 / 2
3.6	Front wheel gauge	b10	517 mm
3.7	Rear wheel gauge	b11	421 mm
Dimensions			
4.2	Mast lowered height	h1	2030 mm
4.5	Mast extended height	h4	3400 mm
4.9	Height tiller min. / max.	h14 / h14	850 mm / 1350 mm
4.15	Fork height in low position	h13	90 mm
4.19	Overall length	l1	1817 mm
4.20	Length to face of forks	l2	667 mm
4.21	Overall width	b1	806 mm
4.22	Forks section / width / length	s / e / l	70 mm x 80 mm / 1150 mm
4.25	Fork spread	b5	560 mm
4.26	Distance between wheel arms/loading surfaces	b4	290 mm
4.24	Fork carriage width	b3	700 mm
4.32	Ground clearance at centre of wheelbase	m2	20 mm
4.34	Aisle width for 800 x 1200 pallet lengthways	Ast	2234 mm
4.35	Turning radius	Wa	1346 mm
Performances			
5.1	Travel speed (laden / unladen)		3.50 km/h / 5 km/h
5.2	Lifting speed (laden / unladen)		0.12 m/s / 0.20 m/s
5.3	Lowering speed (laden / unladen)		0.12 m/s / 0.10 m/s
5.7	Gradeability (laden / unladen)		3.50 % / 5 %
5.10	Service brake		Electro magnetic
5.11	Parking brake		Handle Release
Engine			
6.1	Drive motor rating S2 60 min		0.30 kW
6.2	Lift motor rating at S3 15%		2 kW
6.3	Battery according to DIN 43531/35/36 A, B, C		Semi-Traction
6.4	Battery voltage / capacity		24 V / 85 Ah
6.5	Battery weight (+/- 5%)		50 kg
7.2	Power		0.30 kW
Miscellaneous			
8.1	Type of drive control		AC
8.4	Sound level at the driver's ear according to DIN 12 053		65 dB

Stacky 10 D28 - Dimensional drawing

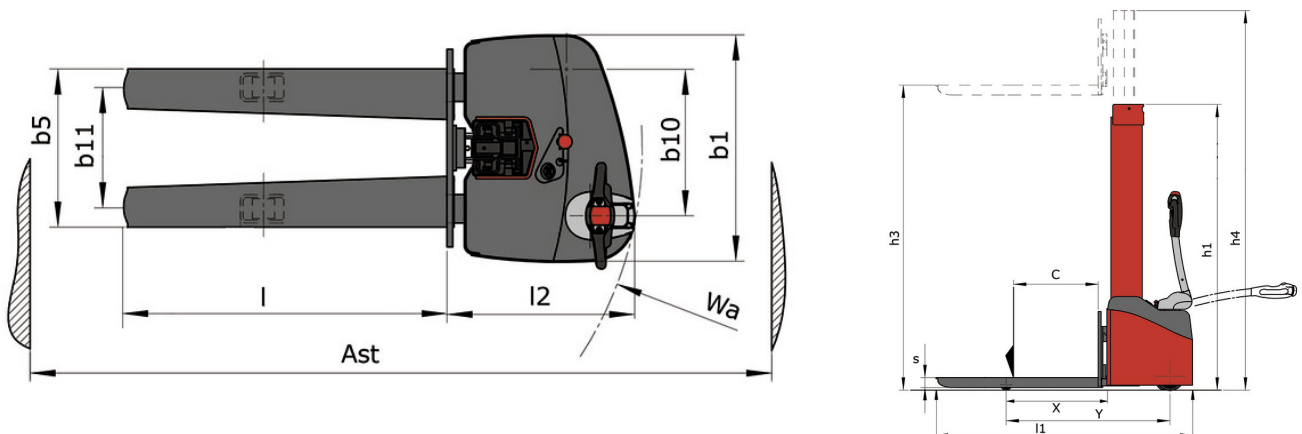

Tool characteristics

Tool 1,000 kg	Attachment capacity kg	Center of gravity of load mm	A1 mm	A2 mm	B mm	B1 mm	C mm	D mm	E mm	E1 mm	E2 mm	F mm	Weight kg
EPE 1000	1000	350	700	730	60	-	-	245	-	-	-	320	38
FA 1000	1000	500	950	1017	-	190	710	45	80	40	-	730	123
FR 1000	1000	600	1150	1182	560	200	320	90	-	70	-	700	82
FUT 1000	300	600	795	600	1057	350	650	245	-	240	631	-	92
PLF 1000	1000	350	700	727	600	-	-	275	-	91	-	630	65
POT 1000	500	600	625	652	50	-	-	145	-	-	-	320	33

Tools

EPE 1000

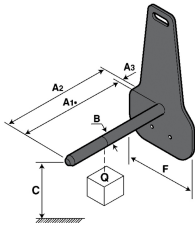

FA 1000

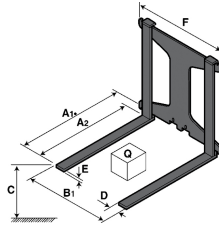

FR 1000

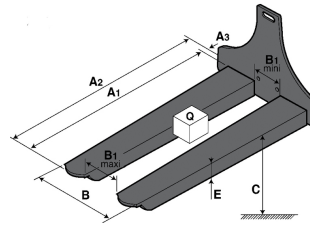

FUT 1000

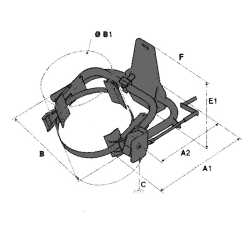

PLF 1000

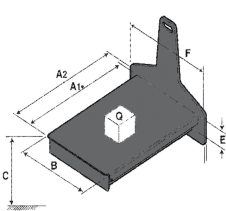

POT 1000

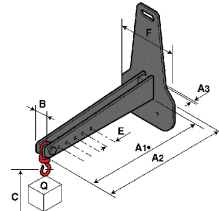



Head Office

B.P. 249 - 430 rue de l'Aubinière

44150 Ancenis Cedex - France

Tel: +33 (0)2 40 09 10 11 - Fax: +33 (0)2 40 09 10 97

www.manitou.com



This publication provides a description of the configuration versions and options for Manitou products, which may differ for equipment. The equipment presented in this brochure may be part of a series, as an option, or it may not be available, depending on the versions. Manitou reserves the right, at any time and without notice, to amend the specifications described and represented. The specifications provided do not bind the manufacturer. For more details, please contact your Manitou agent. This is not a contractually binding document. The presentation of the products is not contractually binding. List of specifications non-exhaustive. The logos as well as the visual identity of the company are owned by Manitou and cannot be used without authorisation. All rights reserved. The photos and diagrams contained in this brochure are only provided for consultation and information purposes.

MANITOU BF SA - Limited company with board of directors - Share capital: 39,668,399 euros - 857 802 508 RCS Nantes