

Technical sheet :

STACKY 14



 **MANITOU**
HANDLING YOUR WORLD

Technical characteristics		Metric	
1.1	Manufacturer		Manitou
1.2	Model Name		Stacky 14
1.3	Power source		Electrical
1.4	Operator type		Pedestrian
1.5	Max. capacity	Q	1400 kg
1.6	Load center of gravity	c	600 mm
1.8	Load distance, centre of drive axle to fork	x	689 mm
1.9	Wheelbase	y	1200 mm
Weight			
2.1	Overall weight without tools		442 kg
Wheels			
3.1	Tires type		Polyurethane
3.5.2	Number of drive wheels - Size of drive wheels		1 x 200x80
3.3	Number of load wheels - Size of load wheels		2 x 78x78
3.4	Number of castor wheels		1
3.4	Number of stabilizer wheels / Size of the stabilizer wheels		1 x 125x50
3.5	Number of front wheels / rear wheels		1 / 2
3.6	Front wheel gauge	b10	517 mm
3.7	Rear wheel gauge	b11	388 mm
Dimensions			
4.2	Mast lowered height	h1	1331 mm
4.5	Mast extended height	h4	1331 mm
4.9	Height tiller min. / max.	h14 / h14	850 mm / 1350 mm
4.15	Fork height in low position	h13	80 mm
4.19	Overall length	l1	1820 mm
4.20	Length to face of forks	l2	680 mm
4.21	Overall width	b1	806 mm
4.22	Forks section / width / length	s / e / l	60 mm x 178 mm / 1150 mm
4.25	Fork spread	b5	566 mm
4.26	Distance between wheel arms/loading surfaces	b4	270 mm
4.24	Fork carriage width	b3	680 mm
4.32	Ground clearance at centre of wheelbase	m2	22 mm
4.34	Aisle width for 800 x 1200 pallet lengthways	Ast	2070 mm
4.35	Turning radius	Wa	1385 mm
Performances			
5.1	Travel speed (laden / unladen)		4.50 km/h / 5 km/h
5.2	Lifting speed (laden / unladen)		0.10 m/s / 0.18 m/s
5.3	Lowering speed (laden / unladen)		0.10 m/s / 0.07 m/s
5.7	Gradeability (laden / unladen)		5 % / 8 %
5.10	Service brake		Electro magnetic
5.11	Parking brake		Handle Release
Engine			
6.1	Drive motor rating S2 60 min		0.50 kW
6.2	Lift motor rating at S3 15%		2 kW
6.3	Battery according to DIN 43531/35/36 A, B, C		Semi-Traction
6.4	Battery voltage / capacity		24 V / 85 Ah
6.5	Battery weight (+/- 5%)		50 kg
Miscellaneous			
8.1	Type of drive control		AC
8.4	Sound level at the driver's ear according to DIN 12 053		65 dB

Stacky 14 - Dimensional drawing

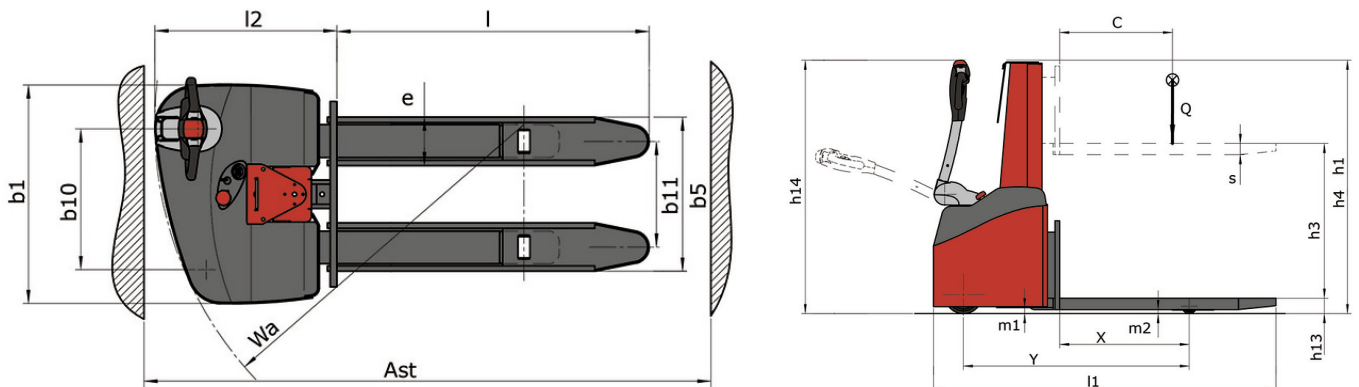



Head Office

B.P. 249 - 430 rue de l'Aubinière

44150 Ancenis Cedex - France

Tel: +33 (0)2 40 09 10 11 - Fax: +33 (0)2 40 09 10 97

www.manitou.com



This publication provides a description of the configuration versions and options for Manitou products, which may differ for equipment. The equipment presented in this brochure may be part of a series, as an option, or it may not be available, depending on the versions. Manitou reserves the right, at any time and without notice, to amend the specifications described and represented. The specifications provided do not bind the manufacturer. For more details, please contact your Manitou agent. This is not a contractually binding document. The presentation of the products is not contractually binding. List of specifications non-exhaustive. The logos as well as the visual identity of the company are owned by Manitou and cannot be used without authorisation. All rights reserved. The photos and diagrams contained in this brochure are only provided for consultation and information purposes.

MANITOU BF SA - Limited company with board of directors - Share capital: 39,668,399 euros - 857 802 508 RCS Nantes